

RTE-V850/SA1-IE

Hardware User's Manual

RealTimeEvaluator

CONTENTS

- 1. INTRODUCTION2
- 2. MAIN FEATURES3
- 3. HARDWARE SPECIFICATION4
- 4. SYSTEM CONFIGURATION5
- 5. INSTALLATION6
- 6. SETTING THE DIP SWITCH7
- 7. DISPLAY LED7
- 8. CONNECTING WITH THE USER SYSTEM8
 - Switching power on 8
 - Switching power off 8
- 9. PRECAUTIONS 10
 - Precautions for connecting the user system 10
 - Handling the RTE-V850/SA1-IE 10
 - Confirming connection with the host system 10
 - Differences between the RTE-V850/SA1-IE and the V850/SA1 (real chip) 10
 - Cautions related to delay time 11
 - NQPACK set consumables 11

1. INTRODUCTION

The RealTimeEvaluator-V850/SA1-IE (hereafter called the RTE-V850/SA1-IE) is an in-circuit emulator for the NEC RISC microcomputer V850/SA1. Using a dedicated emulator chip in the RTE-V850/SA1-IE has made it highly transparent, compact, and lightweight.

The RTE-V850/SA1-IE is supported by two debug monitors, GHS's Multi and Kyoto Microcomputer's PARTNER. Users can select either debug monitor according to the operating environment of their system. Both monitors run on Windows 95.

The host system for the RTE-V850/SA1-IE must be the PC98 series or DOS/V machine that has the environment in which either of the debug monitors mentioned above can run. The host system and the RTE-V850/SA1-IE are connected via the interface card for a dedicated PCMCIA card or for the desktop machine.

The RTE-V850/SA1-IE is supposed to come with the following items. Make sure that you received all these items.

1. RTE-V850/SA1-IE main unit : One each
2. RTE for Win32 setup disk : One each
3. User's manual : One each
4. Grounding clip : One each
5. RTE-PS01 power supply unit: One each
6. NQPACK set : One each

In addition to the above items, the following are required in using the RTE-V850/SA1-IE. They are not standard accessories.

7. Interface kit (interface card and cable set) selected from:
 - PC card interface kit
 - PC98 desktop PC interface kit
 - DOS/V desktop PC interface kit
8. Debugger selected from:
 - GHS C + Multi + Midas server
 - PARTNER/Win

2. MAIN FEATURES

One of two source-level debuggers can be selected.

Users can select either Multi of Green Hills Software (GHS) or PARTNER of Kyoto Microcomputer.

GHS's Multi supports seamless debugging in an C/C++ integrated environment. Meanwhile, PARTNER supports the C language of both GHS and NEC (CA850), allowing users to set up the tool environment as they like.

Both debuggers are provided with sufficient functions as a high-level language debugger. Simply clicking the mouse on the source enables running programs, setting break points, and inspecting variables.

Highly transparent emulation functions are provided.

Use of a dedicated emulation chip in the RTE-V850/SA1-IE enables controlling emulation without using functions in the V850/SA1. Almost all signal lines can be connected directly to the chip. As a result, the emulation functions are provided with both functionally and electrically high transparency.

The standard configuration provides a sufficient emulation memory capacity.

The standard memory configuration of the RTE-V850/SA1-IE matches 256 Kbytes of ROM and 8 Kbytes of RAM internal to the V850/SA1 and 2 Mbyte of memory external to the V850/SA1. Any area can be accessed with no wait state.

A realtime trace function is provided.

The RTE-V850/SA1-IE has a realtime trace function useful in debugging a built-in system. The realtime trace function can trace 32K cycles of any types including internal memory access cycles, as driven by events.

A dedicated communication card is available for communication with the host.

Three different communication cards are available. The PC card usable in the RTE-V850/SA1-IE is a Type-2 card specified in PCMCIA Ver2.1/JEIDA Ver4.2. It can be used in the PC98 series and DOS/V machine that have a card slot. In desktop machines, cards based on the C bus and ISA bus can be used.

3. HARDWARE SPECIFICATION

Emulation section

Target device	V850/SA1
Emulation function	
Clock frequency	17 MHz
Clock source	Automatic switching between external and internal clocks (internal: 17 MHz/32.768 kHz)
Internal ROM emulation capacity	256 KB
Internal RAM emulation capacity	8 KB
External memory emulation capacity	2 MB
External memory mapping unit	64 KB ^{*1}
Memory mapping type	RAM, ROM, GUARD, USER
Break function	
Event setting	Execution address condition : 14 points Access cycle condition : 4 points
Step break	Available
Manual break	Available
Fail-safe break	
Write protection	Available
Guard area	Available
Trace function	
Event setting	Execution address condition : 2 points Access cycle condition : 3 points
Trace memory	150 bits x 32K words
Trace delay	0-7FFFh
Time measurement function	
Measurement start	At the beginning of execution
Measurement stop	Till the occurrence of a break
Resolution	2 CPU clock cycles
Maximum measurement time	2*2 ³² CPU clock cycles
Number of functions	1 ch
Internal RAM realtime display	1 KB
Pin mask function	RESET, NMI, WAIT-, HLDRQ
Bus timeout function	Available
Voltage operating range	3.3 V

*1 0x000000-0x0fffff: 1 MB in 64 KB units, 0x100000-0xfffff: 1 MB in 64 KB units or one block (1 MB) only

Host and interface sections

Item	Description
Target host machine	PC-98 series DOS/V machine
Debug monitor	GreenHills : Multi Kyoto Microcomputer : PARTNER/Win
Interface	PC card Type-2 (PCMCIA Ver2.1/JEIDA Ver4.2 or higher), C bus, and ISA bus
Power supply	AC adapter (input = 100 V and output = +5 V, 2 A)

4. SYSTEM CONFIGURATION

The system configuration of this product is shown below.

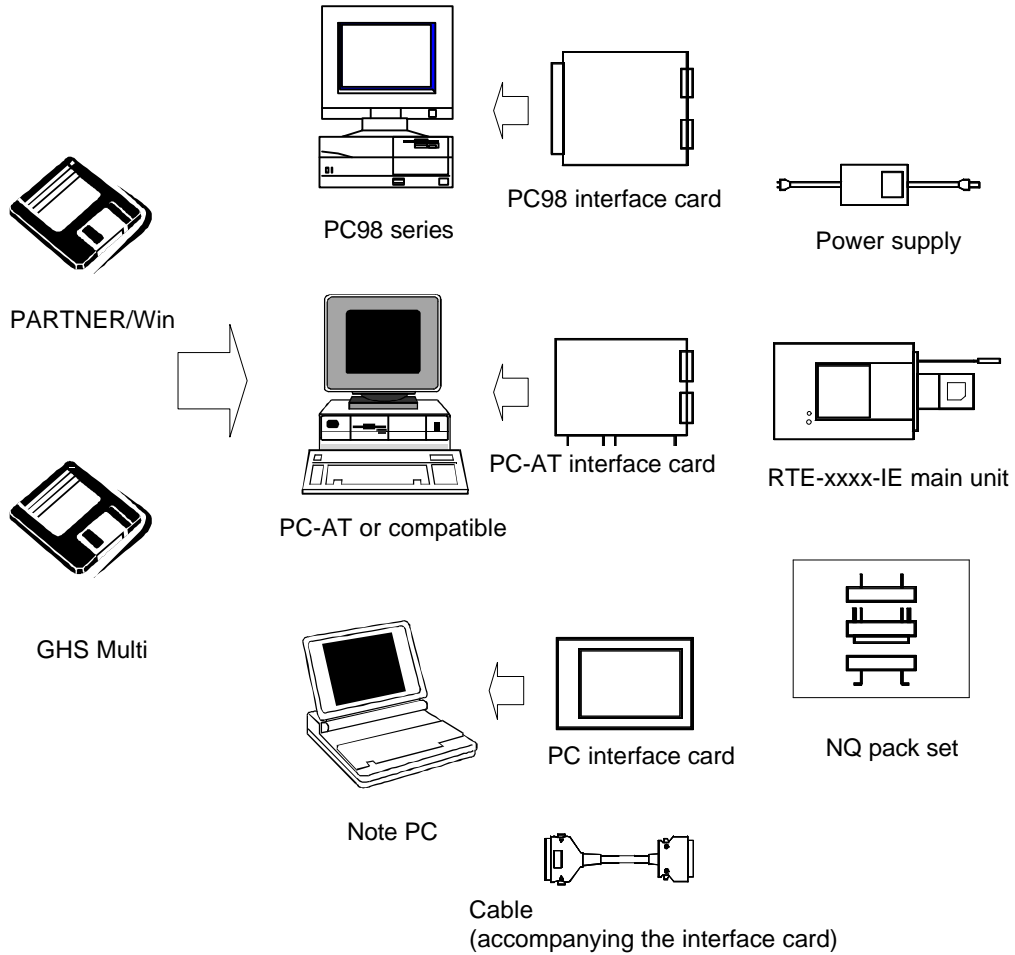

Remark Each PC system must be able to offer an environment in which the debugger to be used can operate.

5. INSTALLATION

The product is installed according to the following procedure.

1. Installing the interface card
 - Refer to the applicable manual for the interface card to be used.
2. Installing RTE for Win32
 - Refer to the applicable manual for RTE for Win32.
3. Initializing RTE for Win32
 - (1) Start chrte32.exe, and initialize the following parameters.

RTE :	V850/SA1-IE	
I/F-1 :		<<Specify the interface card you want to use.
I/F-2 :		<<Specify an IO port as required.

 - Refer to the applicable manual for RTE for Win32 for details.
4. Installing the debug monitor
 - Refer to the applicable manual for the target monitor.
5. Connecting with the user system
 - See Section 8 in this manual.

The setup of this system (exemplifying use of the PC card) is shown below.

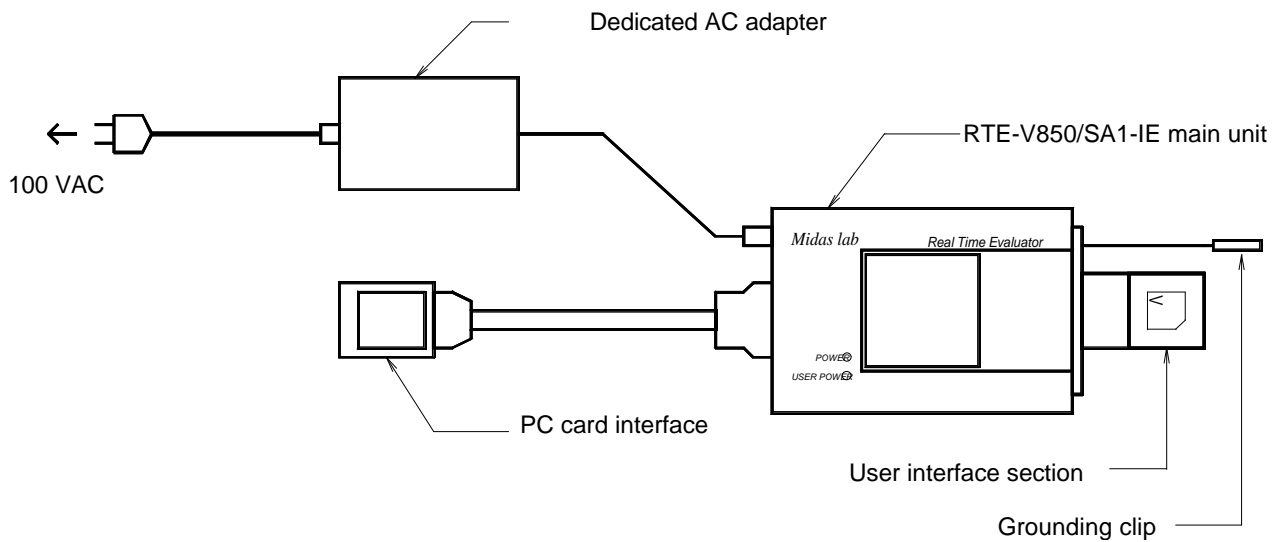

6. SETTING THE DIP SWITCH

A switch on the back of the RTE-V850/SA1-IE is used to specify the emulation mode. It should be set according to the configuration of the user system.

SW1	Symbol	Function	Initial value
1	Factory use	Always ON	ON
2	Factory use	Always OFF	OFF
3	Factory use	Always ON	ON
4	Factory use	Always OFF	OFF
5	Factory use	Always ON	ON
6	CLKAUTO	Used to switch the clock supplied to the V850/SA1	OFF
7	No use	Always OFF	OFF
8	Factory use	Always ON	ON

[CLKAUTO]

This switch contact is used to switch the clock supplied to the V850/SA1.

OFF: The clock pulse is supplied from the user system if it is connected. If the RTE-V850/SA1-IE is used standalone, its internal clock is used.

ON: The internal clock is always used. (The internal clock frequency is 17 MHz.)

[No use]

This switch contact should always be set to OFF.

[Factory use]

This switch contact should always be set to the initial value.

7. DISPLAY LED

The following LEDs are on the top surface of the main unit.

POWER : Lights when the RTE system power is on.

USER POWER : Lights when power is supplied to the user system.

8. CONNECTING WITH THE USER SYSTEM

Connect the RTE-V850/SA1-IE with a personal computer while referring to the applicable manual for the interface kit used between them.

To connect the RTE to the user system, first install its accompanying NQPACK in the user system while referring to the NQPACK technical document, then connect the RTE-V850/SA1-IE.

[Caution]

Before connecting the CPU section, attach a grounding clip leading to the RTE-V850/SA1-IE main unit to a signal ground of the user system.

Switching power on

1. Switch on power to the host personal computer.
2. Connect a power supply dedicated to the RTE to the power supply jack of the RTE-V850/SA1-IE.
3. Switch on power to the user system.
4. Start the debug monitor.

Switching power off

1. Exit the debug monitor.
2. Switch off power for the user system.
3. Remove the power cord from the RTE-V850/SA1-IE power supply jack.
4. Switch off power for the host personal computer.

[Caution]

When connecting the RTE-V850/SA1-IE to the user system, take care about pin 1. If the connection is incorrect, all connected devices may get damaged.

The following figure shows how the RTE-V850/SA1-IE is connected to the user system. For details of the PACK, refer to its accompanying technical document.

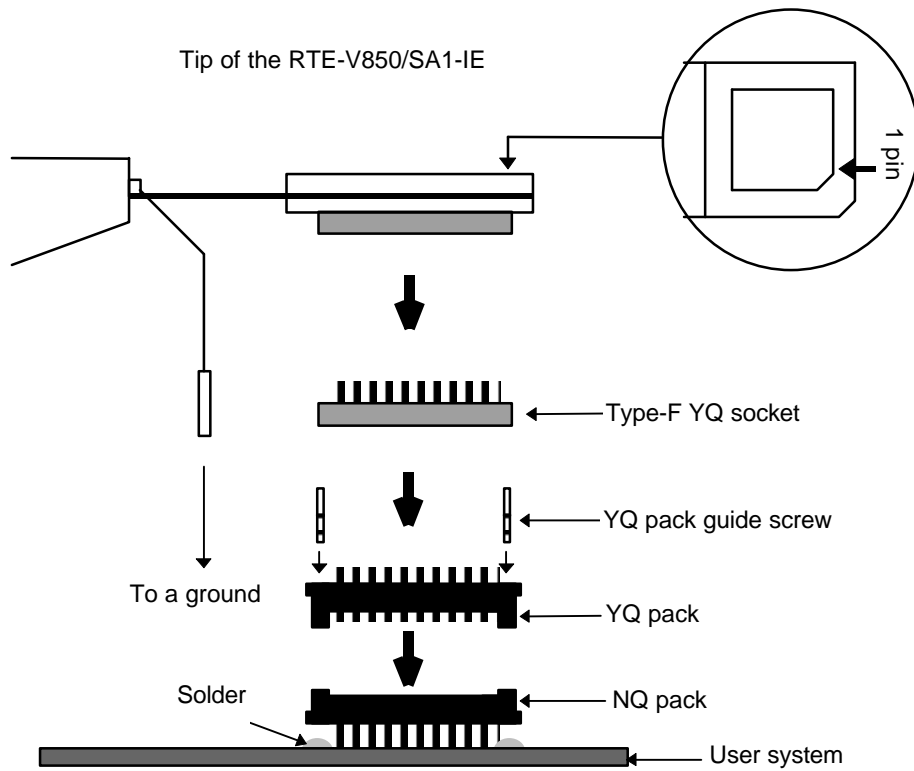

9. PRECAUTIONS

This section summarizes the precautions you should observe when using the RTE-V850/SA1-IE.

Precautions for connecting the user system

- 1) Do not use the RTE-V850/SA1-IE with the user system power switched off. Otherwise, the user system may get damaged or fail to operate normally.
- 2) After the user system power is switched off, if you want to continue using the RTE system, basically restart it from scratch. Otherwise, the RTE system may hang up.
- 3) If the processor in the user system fails to operate normally (because, for example, a reset is active), the RTE system may also fail to start up or may hang up with specific commands.

Handling the RTE-V850/SA1-IE

[Warning]

Do not touch the exposed device on the top surface of the main unit by bare hands. It gets very hot. If you touch it, you may get burned.

[Caution]

The electrodes of the device are connected to the internal power supply. Do not touch it with any electrically conductive stuff. Otherwise, the main unit may get damaged.

Similarly, do not touch exposed socket pins at the bottom of the tip section with metal when power is being supplied. Otherwise, the main unit may get damaged.

Confirming connection with the host system

Immediately after installation, run `chkrte32.exe` to select and set up the host interface card and RTE system, then perform connection tests. Refer to the RTE for Win32 Installation Manual for details.

Differences between the RTE-V850/SA1-IE and the V850/SA1 (real chip)

The real chip does not output CLKOUT immediately after it is reset, while the RTE-V850/SA1-IE outputs CLKOUT. If the user system uses CLKOUT, set software so that CLKOUT is output when the software is stored in ROM.

The real chip allows the memory address output mode register (MAM) to be read and written, while the RTE-V850/SA1-IE allows the register only to be written.

For the RTE-V850/SA1-IE, the subclock is factory-set to 32.768 kHz. Note that an oscillation circuit on the target is not used. Also note that P114, the dual-function pin for XT1, is used as a normal input port even if the subclock is used.

Cautions related to delay time

Almost all signals are connected directly between the CPU in the IE and the user system (see Appendix B). However, a delay of about 3 ns (typical) may occur due to the wiring length required in getting to the tip and the capacity, compared with direct CPU connection. The user system must be designed so as to accommodate this delay.

NQPACK set consumables

- (1) 100-pin type-F YQ socket
YQS-100SDF



- (2) 100-pin YQ pack
YQP-100SD, with guide screws



- (3) 100-pin NQ pack
NQP-100SD



[Remark]

The sockets shown above are consumables. They should be replaced regularly, for example after about 50 cycles of insertion/removal. However, a soldered socket at the lower surface of the RTE-V850/SA1-IE cannot be replaced. If it is expected that it is subjected to frequent insertion/removal, install a 100-pin YQ socket previously for protection purposes.

- Memo -

RTE-V850/SA1-IE Hardware User's Manual	M763MNL01
Created on November 10, 1997. Rev1.00	