

RTE-V852-PC

User' s Manual (Rev. 1.10)

Midas lab

REVISION HISTORY

Date of enforcement	Revision	Chapter	Description
August 15, 1996	1.00		First issue
December 4, 1996	1.10	3.5 8 xx	Correction JPORT2 Pin Arrangement (P21,P21) Correction INT- of JEXT Connector Signals Correction INTP0(P24/INTP03) to INTP0(P22/INTP01)

CONTENTS

1. INTRODUCTION.....	5
1.1. NUMERIC NOTATION	5
2. FEATURES AND FUNCTIONS.....	6
3. BOARD CONFIGURATION.....	7
3.1. RESET SWITCH [SOCKET BOARD] (RESET_SW)	7
3.2. RESET SWITCH [BASE BOARD] (SW_RESET)	7
3.3. NMI SWITCH [SOCKET BOARD] (NMI_SW)	7
3.4. POWER SUPPLY CONNECTOR [SCOKET/BASE BOARD] (JPOWER)	8
3.5. PROCESSOR PIN CONNECTORS [SOCKET BOARD]	9
(JPORT0, JPORT1, JPORT2, JPORT3, JPORT10).....	9
3.6. PROCESSOR PIN CONNECTORS [SOCKET BOARD/BASE BOARD] (J1, J2/J5, J6)10	10
3.7. SERIAL CONNECTOR [SOCKET BOARD] (J3).....	11
3.8. SWITCH 1 [SOCKET BOARD] (SW1)	12
3.9. SWITCH 2 [SOCKET BOARD] (SW2)	12
3.10. CRYSTAL SOCKET [SOCKET BOARD] (JP1)	12
3.11. 7-SEGMENT LED [SOCKET BOARD] (LED_P1)	13
3.12. LEDS [SOCKET BOARD]	13
3.13. SWITCH 1 [BASE BOARD] (SW1)	13
3.14. SWITCH 2 [BASE BOARD] (SW2)	13
3.15. SWITCH 3 [BASE BOARD] (SW3)	14
3.16. ROM CAPACITY SWITCHING JUMPER [BASE BOARD] (JP1)	14
3.17. ISA BUS INTERFACE SWITCHING JUMPER [BASE BOARD] (JP2)	14
3.18. LEDS [BASE BOARD]	14
3.19. TEST PINS FOR ROM EMULATION [BASE BOARD] (JROMEM)	15
3.20. SERIAL CONNECTORS [BASE BOARD] (JSIO1, JSIO2).....	16
3.21. PARALLEL CONNECTOR [BASE BOARD] (JPRT).....	17
3.22. EXTENSION BUS CONNECTOR [BASE BOARD] (JEXT).....	17
3.23. CLOCK SOCKET [BASE BOARD] (OSC1)	17
3.24. DRAM-SIMM SOCKETS.....	18
3.25. ROM SOCKETS	18
4. INSTALLATION AND USE.....	19
4.1. BOARD SETTING	19
4.2. INSTALLATION ON THE ISA BUS.....	22
4.3. STANDALONE USE OF THE BOARD	22

5. HARDWARE REFERENCES	23
5.1 MEMORY MAP	23
6. SYSTEM-I/O.....	25
6.1. SYSTEM-I/O LIST	25
6.2. UART/PRINTER (TL16C552A) (3F-F000H TO 3F-F026H)	26
6.3. TIC (nPD71054) (3F-F030H TO 3F-F038H)	28
6.4. 7-SEGMENT LED DISPLAY DATA OUTPUT PORT (3F-F040H [Write Only])	29
6.5. DIPSW1 READ PORT (3F-F050H [READ ONLY])	29
6.6. STATUS READ PORT (3F-F060H [READ ONLY]).....	30
6.7. BIC (BUS INTERFACE CONTROL) (3F-F080H TO 3F-F0F0H)	31
6.8. NMI SELECT PORT (3F-F140H TO 3F-F150H)	32
6.9. NMI STATUS PORT (3F-F160H TO 3F-F170H [READ ONLY])	34
6.10. NMI/INT0/INT1 MASK PORT (3F-F180H)	34
6.11. NMI/INT1 REQUEST CLEAR PORTS (3F-F190H, 3F-F1A0H [WRITE ONLY])	34
6.12. INT0(P22/INTP01) SELECT PORT (3F-F200H)	35
6.13. INT1 (P24/INTP03) SELECT PORT (3F-F210H)	35
6.14. INT0(P22/INTP01) STATUS PORT (3F-F220H [READ ONLY])	35
6.15. INT1 (P24/INTP03) STATUS PORT (3F-F230H [READ ONLY])	36
7. RECOMMENDED SETTINGS.....	37
7.1. CPU SETTING.....	37
7.2. SRAM/ROM.....	37
7.3. DRAM.....	37
7.4. SYSTEM-I/O WAIT COUNT.....	37
7.5. SYSTEM-I/O COMMAND RECOVERY TIME.....	37
8. JEXT BUS SPECIFICATION.....	39
9. OTHER CPU RESOURCES.....	41
9.1. RESET-	41
9.2. NMI-.....	41
9.3. MASKABLE INTERRUPTS (INT0(P22/INTP01), INT1 (P24/INTP03)).....	43
9.4. PORT	44
10. Multi MONITOR	45
10.1. MONITOR WORK RAM.....	45
10.2. INTERRUPTS.....	45
10.3. _INIT_SP SETTING	45
10.4. REMOTE CONNECTION.....	45
10.5. TIMER INTERRUPT	45

11. RTE COMMANDS	46
11.1. HELP (?)	46
11.2. INIT	46
11.3. VER	46
11.4. SFR	46
12. APPENDIX BUS CYCLE.....	47
12.1. TIME-OVER READY	47
12.2. DRAM INTERFACE	47
12.2.1. <i>Outline</i>	47
12.2.2. <i>Signal Description</i>	47
12.2.3. <i>Single Read (Normal Mode)</i>	48
12.2.4. <i>Single Write (Normal Mode)</i>	49
12.2.5. <i>Page Access (Page Mode, Same Row Address)</i>	50
12.2.6. <i>Page Access (Page Mode, Different Row Addresses)</i>	51
13. APPENDIX CPU PORT CONNECTIONS	52
13.1. P00 TO P07	52
13.2. P10 TO P17	52
13.3. P20 TO P27	52
13.4. P30 TO P37	53
13.5. P100 TO P103	53

1. INTRODUCTION

This manual describes the **RTE-V852-PC**, which is an evaluation board for the V852, NEC' s CPU. With the RTE-V852-PC, it is possible to develop and debug programs, and evaluate the CPU performance, using the GreenHills Multi debugger. Communication with this debugger is carried out using the IBM-PC/AT ISA bus or RS-232C serial interface. It is also possible to expand memory and I/O units using local bus connectors provided on the evaluation board.

1.1. NUMERIC NOTATION

This manual represents numbers according to the notation described in the following table. Hexadecimal and binary numbers are hyphenated at every four digits, if they are difficult to read because of many digits being in each number.

Number	Notation rule	Example
Decimal number	Only numerals are indicated.	" 10" represents number 10 in decimal.
Hexadecimal number	A number is suffixed with letter H.	" 10H" represents number 16 in decimal.
Binary number	A number is suffixed with letter B.	" 10B" represents number 2 in decimal.

Number Notation Rules

2. FEATURES AND FUNCTIONS

The overview of each function block of the RTE-V852-PC is shown below. The RTE-V852-PC consists of the Socket board (smaller board) on which the CPU is mounted, and the Base board on which other components and the Socket board are mounted.

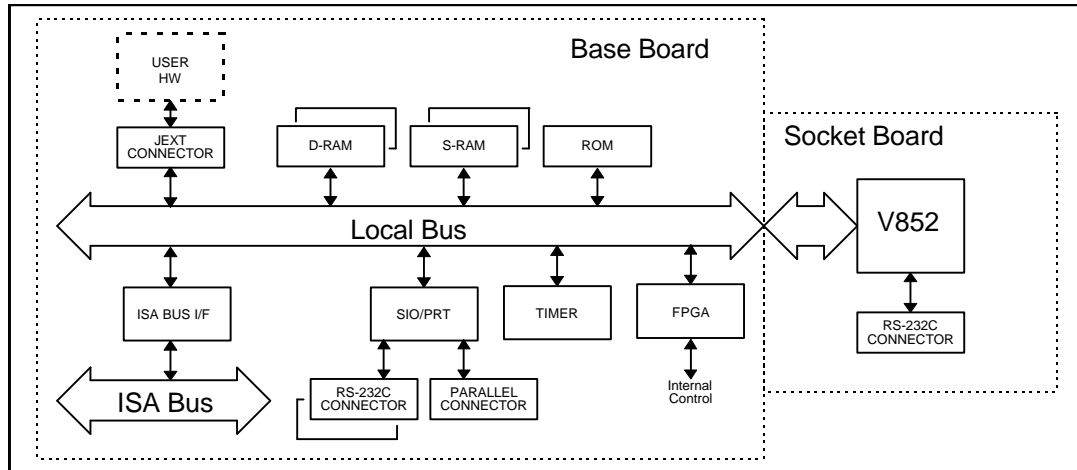

RTE-V852-PC Block Diagram

Features

- ROM: Standard 128 Kbytes (64K × 16-bit EPROM × 1)
Maximum 512 Kbytes (128K × 16-bit EPROM × 1)
- SRAM: 512 Kbytes (64K × 16-bit SRAM × 4)
- DRAM: 4, 8 or 16 Mbytes (standard 4 Mbytes) installed in one 72-pin SIMM socket
The EDO-type DRAM-SIMM can be used as well as the ordinary type DRAM-SIMM.
- RS-232C port (9-pin D-SUB connector × 1, 10-pin 2.54 mm pin header × 2)
- Parallel port (26-pin 2.54-mm pin header × 1)
- Communication function supported using the ISA bus of a PC/AT or compatible
- Local bus connector for user-installed expansion equipment
- Releases CPU ports for the connector.
- External reset switch provided on the rear panel
- Connection pins for ROM in-circuit debugger

3. BOARD CONFIGURATION

The physical layout of the major components on the RTE-V852-PC board is shown below. This chapter explains each component. To use the board with the Multi debugger, first read Chapter 4 before reading this chapter.

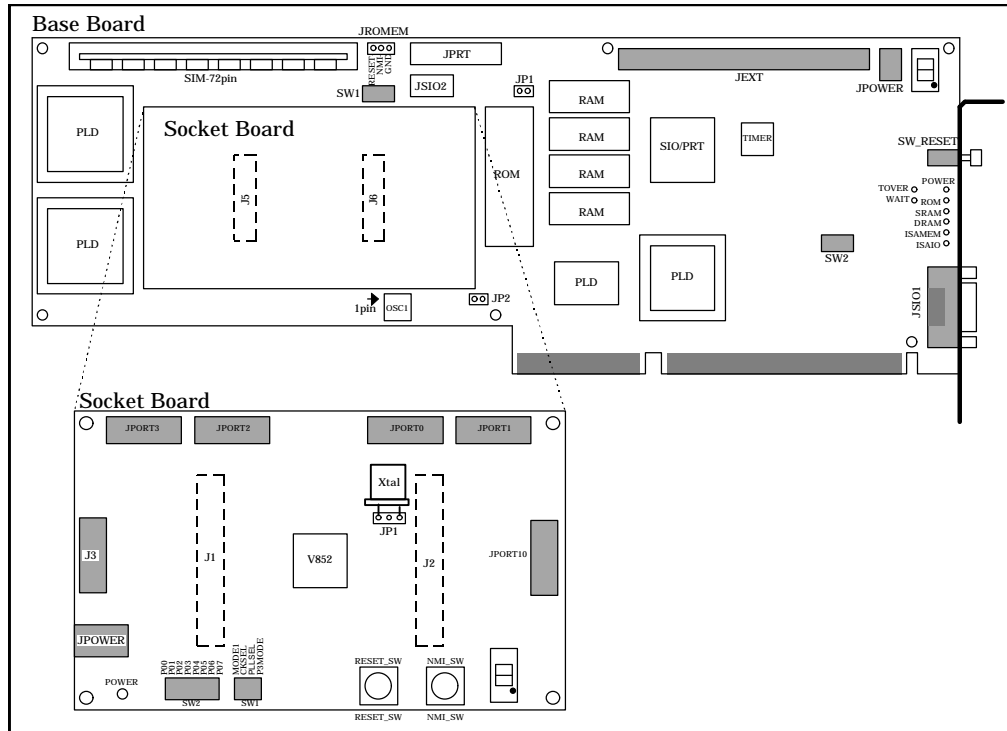

RTE-V852-PC Board Top View

3.1. RESET SWITCH [SOCKET BOARD] (RESET_SW)

RESET_SW on the Socket board is the reset switch. Pressing this switch resets the CPU, and causes the reset signal to be supplied to the Base board. This switch has the same function as the reset switch on the Base board.

3.2. RESET SWITCH [BASE BOARD] (SW_RESET)

SW_RESET on the Base board is the reset switch. Pressing this switch resets the CPU. This switch has the same function as the reset switch on the Socket board.

3.3. NMI SWITCH [SOCKET BOARD] (NMI_SW)

NMI_SW on the Base board is the NMI switch. Pressing this switch causes the level of the NMI pin of the CPU to go Low. As the NMI signal is also provided by the Base board, the NMI signal from this switch is ORed with the NMI signal from the Base board (see Section 9.2).

3.4. POWER SUPPLY CONNECTOR [SOCKET/BASE BOARD] (JPOWER)

When this board is to be used as a standalone, that is, without being inserted in an ISA bus slot, the board should be supplied with power from an external power supply by connecting it to the JPOWER connector.

JPOWER connectors are provided both on the Socket board and on the Base board, but it is recommended that the JPOWER connector on the Base board be used.

The external power should be one rated as listed below.

Voltage: 5 V

Current: Maximum of 2 A (excluding the current supplied to the JEXT connector)

Mating connector: Type A (5.5 mm in diameter)

Polarity:

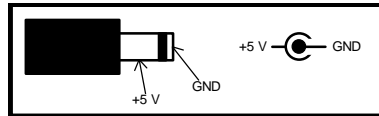

[Caution] When attaching an external power supply to the board, be careful about its connector polarity. When inserting the board into the ISA bus slot, do not attach the JPOWER connector to an external power supply.

3.5. PROCESSOR PIN CONNECTORS [SOCKET BOARD] (JPOR0, JPOR1, JPOR2, JPOR3, JPOR10)

The pins of the CPU are inserted into these connectors. For details of the connections within the board, see Chapter 13.

JPOR0 pin No.	Signal name	JPOR0 pin No.	Signal name
1	GND	2	GND
3	P07/INTP13	4	P06/INTP12
5	P05/INTP11	6	P04/INTP10
7	P03/TI1	8	P02/TCLR1
9	P01/TO11	10	P00/TO10

JPOR0 Pin Arrangement

JPOR1 pin No.	Signal name	JPOR1 pin No.	Signal name
1	GND	2	GND
3	P17	4	P16
5	P15	6	P14
7	P13	8	P12
9	P11	10	P10

JPOR1 Pin Arrangement

JPOR2 pin No.	Signal name	JPOR2 pin No.	Signal name
1	GND	2	GND
3	P27/SCK2-	4	P26/SI2
5	P25/SO2	6	P24/INTP03 ^{Note}
7	P23/INTP02 ^{Note}	8	P22/INTP03 ^{Note}
9	P21/INTP03 ^{Note}	10	NC.

JPOR2 Pin Arrangement

JPOR3 pin No.	Signal name	JPOR3 pin No.	Signal name
1	GND	2	GND
3	P37/SCK1	4	P36/SI1
5	P35/SO1	6	P34/RXD
7	P33/TXD	8	P32/SCK0-
9	P31/SIO	10	P30/SO0

JPOR3 Pin Arrangement

JPOR10 pin No.	Signal name	JPOR10 pin No.	Signal name
1	GND	2	GND
3	NC.	4	NC.
5	NC.	6	NC.
7	P103	8	P102
9	P101/HLDRQ-	10	P100/HLDAK-

JPOR10 Pin Arrangement

Note See Section 3.15.

3.6. PROCESSOR PIN CONNECTORS [SOCKET BOARD/BASE BOARD] (J1, J2/J5, J6)

These connectors are used to connect the Socket board to the Base board.

J1/J5 pin No.	Signal name	J1/J5 pin No.	Signal name
1	GND	2	GND
3	P57/AD15	4	P56/AD14
5	P55/AD13	6	P54/AD12
7	P53/AD11	8	P52/AD10
9	P51/AD9	10	P50/AD8
11	GND	12	GND
13	P47/AD7	14	P46/AD6
15	P45/AD5	16	P44/AD4
17	P43/AD3	18	P42/AD2
19	P41/AD1	20	P40/AD0
21	P22/INTP01	22	P21/INTP00
23	RTE_CON-(IN)	24	1M/16M-(OUT)
25	+5V(IN)	26	+5V(IN)

J1/J5 Pin Arrangement

J2/J6 pin No.	Signal name	J2/J6 pin No.	Signal name
1	GND	2	GND
3	GND(A23)	4	GND(A22)
5	GND(A21)	6	GND(A20)
7	P63(A19)	8	P62(A18)
9	P61(A17)	10	P60(A16)
11	GND	12	GND
13	CLKOUT	14	X1(IN)
15	RESET-(IN/OUT)	16	WAIT-
17	NMI	18	P96/HLDRQ-
19	P95/HLDAK-	20	P94/ASTB
21	P93/DSTB-	22	P92/R_W-
23	P91/UBEN-	24	P90/LBEN-
25	P24/INTP03	26	P23/INTP02

J2/J6 Pin Arrangement

3.7. SERIAL CONNECTOR [SOCKET BOARD] (J3)

The J3 connector is used for the RS-232C interface, controlled by the UART built into the CPU. The pins of this connector have a pitch of 2.54 mm, and the pin arrangement is identical to that of the 9-pin D-SUB RS-232C connector normally provided on the PC/AT when using a push-fit connector with a ribbon cable. All signals at this connector are converted to the RS-232C level.

The pin arrangement of the J3 connector is shown below, after which the signal assignment is listed. For details of the wiring of the connection signals when the board is connected to a PC (or host), see the table in Section 3.20.

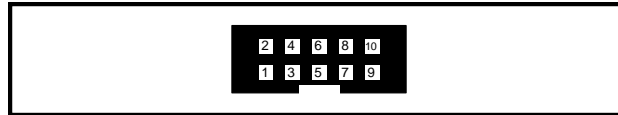

J3 Pin Arrangement

J3 pin No.	Signal name	Input/output	Corresponding port
1	NC	Input	
3	RxD(RD)	Input	P34
5	TxD(SD)	Output	P33
7	DTR(DR) ^{Note}	Output	--
9	GND		
2	DSR(ER)	Input	P37
4	RTS(RS)	Output	P35
6	CTS(CS)	Input	P36
8	NC		
10	NC		

J3 Connector Signals

Note The DTR signal outputs the active level at power-on.

3.8. SWITCH 1 [SOCKET BOARD] (SW1)

SW1 on the Socket board is the switch used for setting the mode.

SW1 contact	1	2	3	4
Port	MODE	CKSEL	PLLSEL	P3MODE

SW1-to-Port Correspondence

- MODE1:** Switch for specifying the operation mode of the V852.
 OFF: Single chip mode
 ON: ROM-less mode (factory-set)
- CKSEL:** Switch for specifying the CKSEL level of the V852.
 OFF: Direct mode
 ON: PLL mode (factory-set)
- PLLSEL:** Switch for specifying the PLLSEL level of the V852.
 OFF: $\times 5$ (factory-set)
 ON: $\times 1$
- P3MODE:** Switch for specifying the mode used by P3 of the V852.
 OFF: Connects P34, P36, and P37 to JPORT3. (factory-set)
 ON: Connects P34, P36, and P37 to J3 (RS-232C).

3.9. SWITCH 2 [SOCKET BOARD] (SW2)

SW2 on the Socket board is connected to CPU Port 0 and can be used freely by the user. When a switch contact is OFF, it represents 1. When it is ON, it represents 0.

[Caution] Set all of the switch contacts to OFF when the P0 terminal is to be used for other purposes.

SW2 contact	1	2	3	4	5	6	7	8
Port	P00	P01	P02	P03	P04	P05	P06	P07

SW2-to-Port Correspondence

3.10. CRYSTAL SOCKET [SOCKET BOARD] (JP1)

JP1 has two roles. Namely, it is used to select the clock supplied to the CPU and also acts as the connector for the crystal oscillator.

When an oscillator is connected to the OSC1 socket on the Base board:

Jumper pins 1 and 2 of JP1. Do not connect a crystal oscillator to JP1 in this case.

When a crystal oscillator is connected to JP1:

Connect the crystal oscillator across pins 1 and 3. Do not jumper pins 1 and 2.

3.11. 7-SEGMENT LED [SOCKET BOARD] (LED_P1)

LED_P1 is a 7-segment LED, to which the P1 ports of the CPU are connected as shown in the table below. When a bit is set to 1, the corresponding segment lights.

Segment	A	B	C	D	E	F	G	D.P.
Port	P10	P11	P12	P13	P14	P15	P16	P17

LED_P1 Correspondence

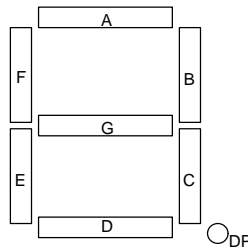

3.12. LEDS [SOCKET BOARD]

The table below explains the LEDs on the Socket board.

Name	Description
LED_POWER	Lights when power is supplied to the board.

LED Status

3.13. SWITCH 1 [BASE BOARD] (SW1)

SW1 is the switch connected to the general-purpose input ports and read by software. When a switch contact is OFF, it represents 1. When it is ON, it represents 0. See Sections 4.1 and 6.5 for details.

3.14. SWITCH 2 [BASE BOARD] (SW2)

SW2 is the switch used for selecting the I/O address of the ISA bus. Switch contacts 1 to 8 correspond to A4 to A11 of the ISA bus address (A12 to A15 are fixed at 0). Therefore, this switch can be used to select an I/O address in the range of 000xH to 0FFxH. When a switch contact is OFF, it represents 1. When it is ON, it represents 0 (see Section 4.1).

SW2 contact	1	2	3	4	5	6	7	8
Address	A4	A5	A6	A7	A8	A9	A10	A11

SW2-to-Address Correspondence

3.15. SWITCH 3 [BASE BOARD] (SW3)

SW3 is the switch used for selecting whether the interrupt factors on the Base board are to be connected to the CPU. The relationship between the switch contact numbers, CPU interrupt pins and interrupt factors is given in the table below. When a switch contact is OFF, it represents no connection. When it is ON, it represents connection to the CPU.

When a signal having the same pin name as one of the CPU pin names listed below is transmitted through the JPORT2 connector, set the corresponding contact of SW3 to OFF.

Usually, set all of the switch contacts to OFF. For INT0SEL and INT1SEL, see Section 9.3.

SW3 contact	CPU pin name	J5/J6 pin No.	Interrupt factor
1	P21/INTP00	J5-Pin 22	Interrupt request of UART2(SCC2) of TL16C552A on Base board. Interrupt is High level.
2	P22/INTP01	J5-Pin 21	Interrupt request on Base board that is selected with INT0SEL. Interrupt is High level.
3	P23/INTP02	J6-Pin 26	Inverted signal of JEXT bus interrupt request signal (INT-). Interrupt is High level.
4	P24/INTP03	J6-Pin 25	Interrupt request on Base board that is selected with INT1SEL. Interrupt is High level.

SW3-to-Interrupt Correspondence

3.16. ROM CAPACITY SWITCHING JUMPER [BASE BOARD] (JP1)

JP1 is the jumper to be set according to the capacity of the mounted ROM. Leave it open when mounting 128 Kbytes (64K × 16-bit) or 256 Kbytes (128K × 16-bit) of ROM. Close the jumper when mounting 512 Kbytes (256K × 16-bit) of ROM.

3.17. ISA BUS INTERFACE SWITCHING JUMPER [BASE BOARD] (JP2)

JP2 is the jumper for switching the mode of the interface with the ISA bus. This jumper should normally be left open.

3.18. LEDS [BASE BOARD]

These LEDs are used for status indication. The LEDs are explained in detail in the table below.

Name	Description
POWER	Lights when power is supplied to the board.
ROM	Lights when the ROM area is selected.
SRAM	Lights when the SRAM area is selected.
DRAM	Lights when the DRAM area is selected.
TOVER	Lights when a time-over ready interrupt occurs and remains lit until the time-over ready interrupt is cleared by software. (See Section 12.1.)
WAIT	Lights when a wait cycle occurs as a result of a cycle being generated in the external extension bus. The brightness of the LED corresponds to the wait cycle frequency.
ISAMEM	Lights when the ISA memory area is selected.
ISAIO	Lights when the ISA I/O area is selected.

LED Status

3.19. TEST PINS FOR ROM EMULATION [BASE BOARD] (JROMEM)

JROMEM are the test pins used to connect a ROM in-circuit type debugger. These test pins accept control signals from the ROM in-circuit debugger. The signal names and functions are listed in the table below.

Signal name	Input/output	Function
RESET-	Input	Connects the reset request signal from the ROM in-circuit debugger. The CPU is reset when a Low level signal is input. The input is pulled up by a 1 k Ω resistor on the board.
NMI-	Input	Connects the NMI request signal (break request) from the ROM in-circuit debugger. The NMI is input to the CPU when a Low level signal is input. The input is pulled up by a 1 k Ω resistor on the board. (See Section 9.2.)
GND	-----	Ground pin to ground the ROM in-circuit debugger.

Test Pin Functions

3.20. SERIAL CONNECTORS [BASE BOARD] (JSIO1, JSIO2)

The JSIO1 and JSIO2 connectors are used for the RS-232C interface controlled by the serial controller (TL16C552A). Regarding the connector shapes, JSIO1 is a 9-pin D-SUB RS-232C connector like that normally provided on the PC/AT, while JSIO2 is a pin header type connector with a pitch of 2.54 mm. All signals at both of these connectors are converted to RS-232C level. The pin arrangements of these connectors are shown below, after which the signal assignments are listed.

For the connection signals when the connectors are connected to the host, the table lists the wiring for both the D-SUB 9 pins and D-SUB 25 pins on the host side. (Regular cross-cable wiring is used for these connections.)

The pin arrangement of JSIO2 is identical to that of JSIO1 when a push-fit connector with a ribbon cable is connected to JSIO2.

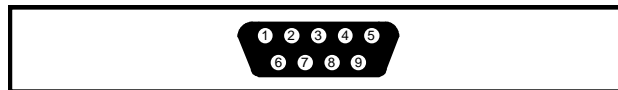

JSIO1 Pin Arrangement

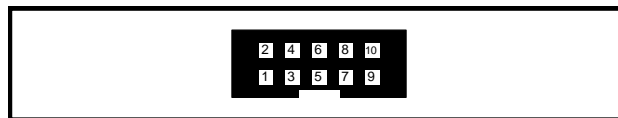

JSIO2 Pin Arrangement

JSIO1 pin No.	JSIO2 pin No.	Signal name	Input/output	Connector pin No. on the host side	
				D-SUB9	D-SUB25
1	1	DCD	Input		
2	3	RxD(RD)	Input	3	2
3	5	TxD(SD)	Output	2	3
4	7	DTR(DR)	Output	1, 6	6, 8
5	9	GND		5	7
6	2	DSR(ER)	Input	4	20
7	4	RTS(RS)	Output	8	5
8	6	CTS(CS)	Input	7	4
9	8	RI	Input		
--	10	NC			

JSIO1/2 Connector Signals

3.21. PARALLEL CONNECTOR [BASE BOARD] (JPRT)

The JPRT connector is used for the parallel interface controlled by the parallel (printer) controller (TL16C552A). It is a pin header type connector with a pitch of 2.54 mm. All signals at this connector are at the RS-232C level. Its pin arrangement and signal assignment are shown and listed below.

The pin arrangement of JPRT is identical to the 25-pin D-SUB connector like that normally provided on the PC/AT when a push-fit connector with a ribbon cable is used.

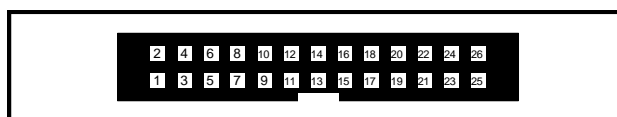

JPRT Pin Arrangement

JPRT pin No.	Signal name	JPRT pin No.	Signal name
1	STB-	2	AUTO_FD-
3	D0	4	ERROR-
5	D1	6	INIT-
7	D2	8	SELECT_IN-
9	D3	10	GND
11	D4	12	GND
13	D5	14	GND
15	D6	16	GND
17	D7	18	GND
19	ACK-	20	GND
21	BUSY	22	GND
23	PE	24	GND
25	SELECT	26	NC

JPRT Connector Signals

3.22. EXTENSION BUS CONNECTOR [BASE BOARD] (JEXT)

The JEXT connector is provided to enable the extension of memory or I/O. This connector is internally connected to the local bus of the Base board. For details of this connector, see Chapter 8.

3.23. CLOCK SOCKET [BASE BOARD] (OSC1)

The OSC1 socket is connected to an oscillator used to supply clock pulses to the CPU. At the factory setting, the V852 uses a PLL for generating the system clock, and the CPU clock frequency is five times that of the oscillator connected to the OSC1 socket.

The clock supplied to the CPU can also be obtained from a crystal oscillator connected to JP1 on the Socket board. (See Section 3.10).

The oscillator connected to the OSC1 socket must be of an 8-pin DIP type (half type).

[Caution] When the OSC1 socket is used, short pins 1 and 2 of JP1 on the socket board.

3.24. DRAM-SIMM SOCKETS

A 4-Mbyte SIMM is mounted in the DRAM-SIMM socket as standard. This socket can hold a 72-pin SIMM (known as a module in the case of DOS/V machines) with a capacity of 4 or 8 Mbytes, and can also accept an EDO type DRAM-SIMM in addition to normal DRAM-SIMMs. Select a DRAM that satisfies the access timing requirements by referring to Section 7.3. The capacity of the connected SIMM can be read through the PIO port. (See Section 6.6.)

3.25. ROM SOCKETS

The RTE-V852-PC has ROM sockets to hold 40-pin ROM chips to provide standard 128 Kbytes (64K × 16 bits). When the standard ROM is replaced to enable the use of a Multi debugger, connect ROM having an access time of no more than 150 ns. When mounting RAM of a different capacity, it may sometimes be necessary to switch JP1 on the Base board. (See Section 3.16.)

4. INSTALLATION AND USE

The RTE-V852-PC board is designed to be installed in the ISA bus slot of a PC/AT or compatible (hereafter called the PC). However, it can also be used as a standalone, if it is powered from an external power supply. When the board is used for testing purposes or with the Multi debugger, communication software called RTE for Windows must be installed in the PC. Refer to the **RTE for Windows Installation Manual** for installation and test methods.

4.1. BOARD SETTING

The RTE-V852-PC board has DIP switches. The DIP switches can be used to set up the evaluation board. The switch layout is shown below.

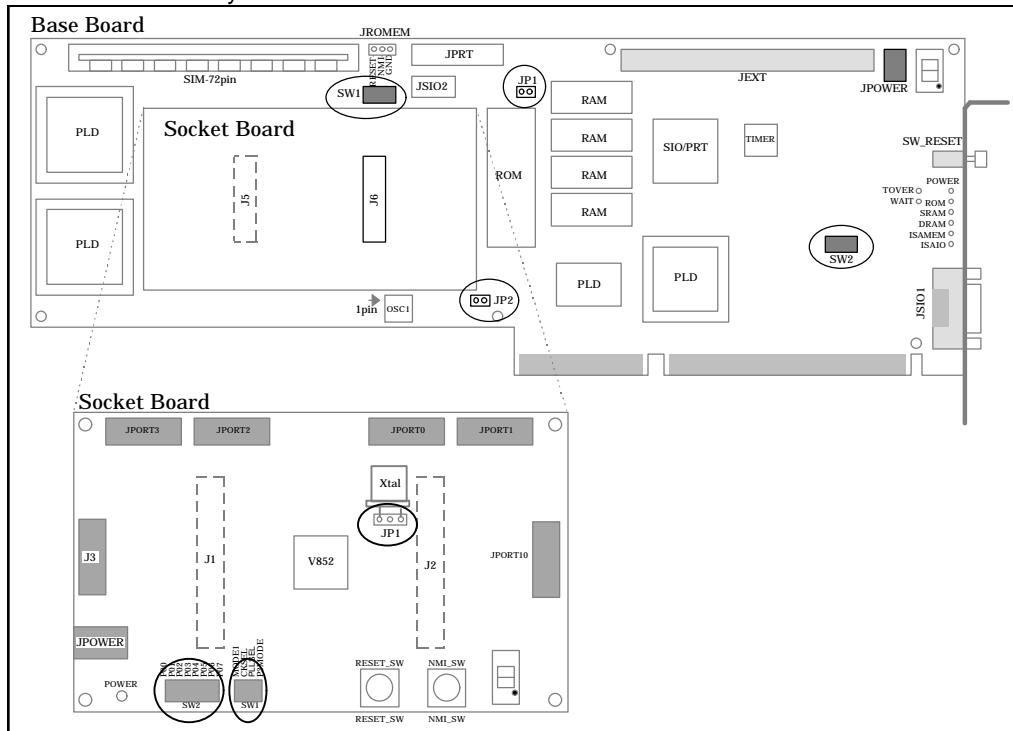

Switches on the RTE-V852-PC Board

SW1 on the Base board is a switch for general-purpose input ports. For the Multi monitor in the factory-installed ROM, SW1 is used to set the RS-232C baud rate and profiler timer period.

SW1 contact	1	2	Baud rate
Setting	ON	ON	Not used
	OFF	ON	38400 baud
	ON	OFF	19200 baud
	OFF	OFF	9600 baud (factory-set)

Baud Rate Setting

SW1 contact	3	4	Profiler period
Setting	ON	ON	Timer is not used. ^{Note}
	OFF	ON	200 Hz 5 ms
	ON	OFF	100 Hz 10 ms
	OFF	OFF	60 Hz 16.67 ms (factory-set)

Note: Do not set this contact when using a Multi debugger. (See Section 10.5.)

Profiler Period Setting

Contacts 5 to 8 of SW1 on the Base board are not used by the Multi monitor (they are factory-set to OFF prior to shipment).

SW2 on the Base board is used to select the I/O bus of the ISA bus. Switch contacts 1 to 8 correspond to A4 to A11 of the address (A12 to A15 are fixed at 0). Therefore, this switch can be used to select an I/O address in the range of 000xH to 0FFxH. When a switch contact is OFF, it represents 1. When it is ON, it represents 0. The address is usually set to between 20xH and 3F xH.

SW2 contact	1	2	3	4	5	6	7	8	
Address	A4	A5	A6	A7	A8	A9	A10	A11	I/O Address
ON/ OFF	0	0	0	0	0	1	0	0	020xH (factory-set)

I/O Address Correspondence

SW3 on the Base board is set to ON when the interrupt request line on the Base board is connected to a CPU pin. Normally, set all of contacts 1 to 4 to OFF. (See Section 3.15.)

JP1 and **JP2** on the Base board should normally be left open. JP1 may have to be switched when ROM having a different capacity from the standard is mounted. (See Sections 3.16 and 3.17.)

SW1 on the Socket board is used to select the CPU mode and the connection of CPU Port 2 (see Section 3.8). The default settings are listed in the tables below.

SW1-1	Description
ON	Sets the operation mode of the V852 to ROM-less. (Built-in ROM is disabled and the external extension bus is enabled.)

SW1-2	Description
ON	(CKSEL = Low)

SW1-3	Description
OFF	(PLLSEL = High)

SW1-4	Description
OFF	(Connects P34, P36, and P37 to JPORT2.)

SW2 on the Socket board selects the level of the signals supplied to Port 0 and can be used as desired by the user. The factory-set default is all OFF (see Section 3.9).

JP1 on the Socket board determines the clock supplied to the CPU. Connect a 6.6-MHz crystal

oscillator to JP1. When the clock must be changed, see Section 3.10.

4.2. INSTALLATION ON THE ISA BUS

When the RTE-V852-PC is installed in the ISA bus slot of the PC, power (+5 V) is supplied from the ISA bus to the board. In addition, the ISA bus can be used for communication with the debugger, so programs are down-loaded at high speed.

The RTE-V852-PC can be installed in the ISA bus slot according to the following procedure.

- ① Set the I/O address of the PC using a DIP switch on the board. Be careful not to specify the same I/O address as used for any other I/O unit. See Section 4.1 for switch setting.
- ② Turn off the power to the PC, open its housing, and confirm the ISA bus slot to be used. If the slot is equipped with a rear panel, remove the rear panel.
- ③ Insert the board into the ISA bus slot. Make sure that the board does not touch any adjacent board. Fasten the rear panel of the board to the housing of the PC with screws.
- ④ Turn on the power to the PC, and check that the POWER-LED on the board lights. **If the LED does not light, turn off the PC power immediately, and check the connection.** If the system does not start normally (for example, if an error occurs during installation of a device driver), it is likely that the set I/O address is the same as one already in use. Reconfirm the I/O address of the board by referring to the applicable manual of the PC or the board.
- ⑤ When the system turns out to be normal, turn off the PC power again, and put back its housing.

4.3. STANDALONE USE OF THE BOARD

When the RTE-V852-PC is used as a standalone rather than being installed in the PC, it requires an external power supply. In addition, communication with the debugger is supported only by the RS-232C interface. This configuration is useful when the host debugger used with the board is not one in the PC/AT or compatible as well as when the board is used for hardware confirmation and expansion.

The RTE-V852-PC can be used as a standalone according to the following procedure.

- ① Get an RS-232C cable for connection with the host and an external power supply (+5 V, 2 A) on hand. Especially for the power supply, watch for its voltage and **connector polarity**. In addition, attach spacers to the four corners of the board, so it will not pose any problem wherever it is installed. See Sections 3.20 and 3.4 for RS-232C cable connection and the power supply connector, respectively.
- ② Set the RS-232C baud rate using a DIP switch on the board. See Section 4.1 for switch setting.
- ③ Connect the board to the host via an RS-232C cable. Also connect an external power supply to the JPOWER connector, then check that the POWER-LED on the board lights. **If the LED does not light, turn off the power immediately, and check the connection.**

5. HARDWARE REFERENCES

This chapter describes the hardware of the RTE-V852-PC.

5.1 MEMORY MAP

The memory assignment of the board is shown below.

As the CPU of the V852 includes built-in resources, the built-in resources appear in place of the external resources in those spaces where the built-in resources exist. More precisely, built-in ROM appears between 00-0000H and 0F-FFFFH (only when the CPU is in single-chip mode), built-in RAM appears between FF-E000H and FF-EFFFH and the built-in peripheral I/O appears between FF-F000H and FF-FFFFH.

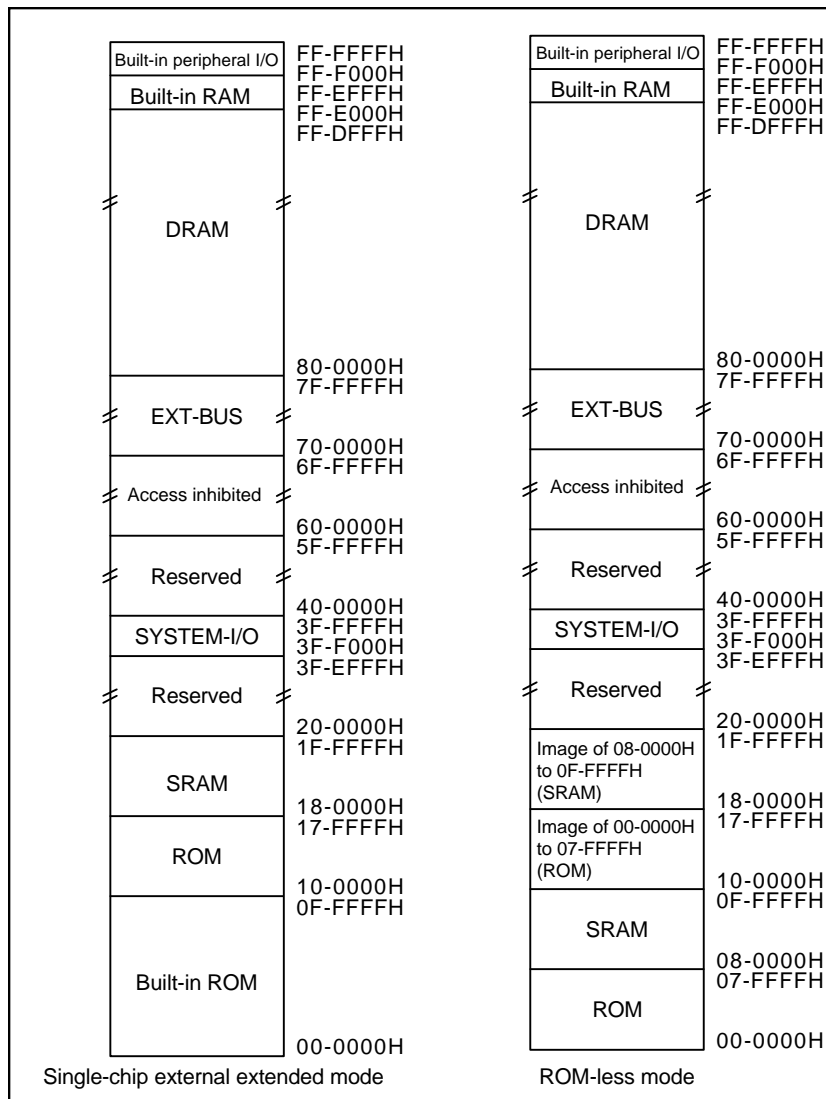

Memory Map

ROM space (00-0000H to 07-FFFFH, 10-0000H to 17-FFFFH)

This 512-Kbyte space is provided as ROM on the Base board. The standard ROM has a capacity of 256 Kbytes and an access time of no more than 150 ns. The ROM is capable of inserting wait states into the access cycle based on ready signal control, and the wait count can be set with SYSTEM-I/O (see Section 6.7). For details of the required wait count, see Section 7.2.

The ROM on the Base board incorporates the Multi debugger monitor as standard.

SRAM space (08-0000H to 0F-FFFFH, 18-0000H to 1F-FFFFH)

This 512-Kbyte space is provided as SRAM on the Base board. The SRAM is capable of specifying wait states and the wait count can be set with SYSTEM-I/O (see Section 6.7). For details of the required wait count, see Section 7.2.

Reserved and access-inhibited spaces

Do not attempt to access these spaces.

SYSTEM-I/O space (3F-F000H to 3F-FFFFH)

This space is assigned to I/O devices for controlling each function on the base board. It acts as memory-mapped I/O units. See Chapter 6 for details.

EXT-BUS space (70-0000H to 7F-FFFFH)

This space is used for a hardware extension board connected to the JEXT connector on the board. See Chapter 8 for details of EXT-BUS.

DRAM space (80-0000H to FF-FFFFH)

This space is provided by the 72-pin SIMM mounted on the Base board. SIMM memory of 4, 8 or 16 Mbytes can be mounted. Also, an EDO-DRAM SIMM can be mounted. It is possible to specify RAS, CAS and precharge widths (see Section 6.7). The type of the mounted SIMM can be identified from PD[1..4] of the Status port (see Section 6.6).

6. SYSTEM-I/O

SYSTEM-I/O is an I/O device mapped in a memory space. The I/O devices include the UART/PRINTER, TIC, PIO, and ISA bus interface. (No description about the ISA bus interface is included.)

6.1. SYSTEM-I/O LIST

The following table lists the SYSTEM-I/O functions.

Address	Function	Note
3F-F000H to 3F-F00EH	Sets/references UART-CH#1 (TL16C552A)	Recovery time is required.
3F-F010H to 3F-F01EH	Sets/references UART-CH#2 (TL16C552A)	Recovery time is required.
3F-F020H to 3F-F026H	Sets/references PRINTER (TL16C552A)	Recovery time is required.
3F-F030H to 3F-F036H	Sets/references timer controller (nPD71054)	Recovery time is required.
3F-F040H	Sets Base board 7-segment LED display data	
3F-F050H	References Base board DIPSW1	
3F-F060H	References status (DRAM-PD, time-over flag, etc.)	
3F-F080H	Sets/references SRAM wait state	
3F-F0A0H	Sets/references DRAM precharge time	
3F-F0B0H	Sets/references DRAM RAS width	
3F-F0C0H	Sets/references DRAM read-cycle CAS width	
3F-F0D0H	Sets/references DRAM page mode	
3F-F0E0H	Sets/references SYSTEM-I/O wait state	
3F-F0F0H	Sets/references ROM wait state	
3F-F100H	-----	Reserved
3F-F110H	-----	Reserved
3F-F140H to 3F-F150H	Sets/references NMI selection	
3F-F160H to 3F-F170H	References NMI status	
3F-F180H	Sets/references NMI, INT0 and INT1 masking	
3F-F190H	Clears time-over ready flag	
3F-F1A0H	Clears nPD71054 TOUT0 interrupt request	
3F-F200H	Sets/references INT0 selection	
3F-F210H	Sets/references INT1 selection	
3F-F220H	References INT0 status	
3F-F220H	References INT1 status	

6.2. UART/PRINTER (TL16C552A) (3F-F000H TO 3F-F026H)

The TL16C552A (dual asynchronous communications element with FIFO) IC produced by Texas Instruments is used as UART/PRINTER. The TL16C552A has two UART channels and one channel of the bidirectional printer board. It incorporates a 16-character FIFO buffer in the UART reception circuitry to minimize the possibility of an overrun error during reception.

Each register in the TL16C552A is assigned as listed below. Refer to the applicable TL16C552A manual for the function of each register.

Address	Function	Read	Write
3F-F000H	UART-CH#1	RBR/DLL	THR/DLL
3F-F002H		IER/DLM	IER/DLM
3F-F004H		IIR	FCR
3F-F006H		LCR	LCR
3F-F008H		MCR	MCR
3F-F00AH		LSR	LSR
3F-F00CH		MSR	MSR
3F-F00EH		SCR	SCR
3F-F010H	UART-CH#2	RBR/DLL	THR/DLL
3F-F012H		IER/DLM	IER/DLM
3F-F014H		IIR	FCR
3F-F016H		LCR	LCR
3F-F018H		MCR	MCR
3F-F01AH		LSR	LSR
3F-F01CH		MSR	MSR
3F-F01EH		SCR	SCR
3F-F020H	PRINTER	Read-data	Write-data
3F-F022H		Read-status	-----
3F-F024H		Read-control	Write-control
3F-F026H		-----	-----

TL16C552A Register Arrangement

The CLK input of the TLC16C552A is connected to the 16-MHz clock.

RD-WR- pulse widths of 80 ns are required to access the TL16C552A. As a result, wait states should be inserted to satisfy this condition. See Section 7.4 for details of the wait setting value, and Section 6.7 for details of the wait setting position.

The TL16C552A requires 80 ns of command recovery time. See Section 7.5 for details of the recovery time.

The UART-CH#1, UART-CH#2 and PRINTER interrupts can be connected to the CPU's interrupt ports as shown in the following table.

Interrupt source	Interrupt to connected CPU
UART-CH#1	NMI- , P22/INTP01
UART-CH#2	NMI- , P21/INTP00
PRINTER	NMI- , P22/INTP01

Maskable interrupts pass through DIP SW3. See Section 9.2 for details of the NMI-, and Section 9.3 for details of the maskable interrupt.

UART-CH#1 is connected to the JSIO0 connector on the rear of the Base board, UART-CH#2 is connected to the JSIO2 connector and PRINTER is connected to JPRT. UART-CH#1 is used when using the Multi debugger for serial communication.

The TL16C552A is reset when the system is reset (see Section 9.1).

6.3. TIC (nPD71054) (3F-F030H TO 3F-F038H)

The nPD71054 produced by NEC is installed as a TIC. The nPD71054 is compatible with the i8254 produced by Intel. It has three timers/counters. These timers/counters are used to generate the DRAM refresh timing and monitor timer interrupts. Each register of the TIC is assigned as listed below.

Address	Read	Write
3F-F030H	COUNTER#0	COUNTER#0
3F-F032H	COUNTER#1	COUNTER#1
3F-F034H	COUNTER#2	COUNTER#2
3F-F036H	-----	Control Word

TIC Register Arrangement

The channels of the TIC are connected as shown in the figure below.

CH#0 is connected to the NMI generator circuit and is used as the interval timer of the monitor program. At this time, CH#0 also functions as the prescale counter for CH#1.

CH#1 can be used as required by the user program. The status of the CH#0 and CH#1 outputs can be read from the Status port (See Section 6.6).

CH#2 is used to generate the refresh timing. Therefore, the division value of CH#2 should be set to 30 (1EH) in mode 2.

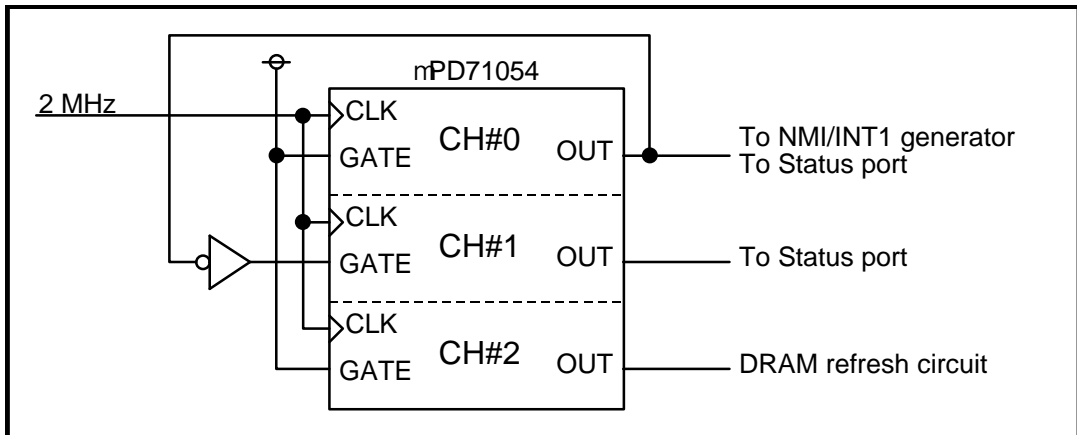

RD-/WR- pulse widths of 95 ns are required to access the nPD71054. As a result, wait states should be inserted to satisfy this condition. See Section 7.4 for details of the wait setting value and Section 6.7 for details of the wait setting position.

The nPD71054 requires 165 ns of command recovery time. See Section 7.5 for details of the recovery time.

The TIC is reset when the system is reset (see Section 9.1).

6.4. 7-SEGMENT LED DISPLAY DATA OUTPUT PORT (3F-F040H [Write Only])

This port sets the data to be displayed on the 7-segment LED on the Base board. The data format is as shown in table below. Setting a bit to 0 causes the corresponding segment to light.

Bit7	Bit6	Bit5	Bit4	Bit3	Bit2	Bit1	Bit0
DPseg	Gseg	Fseg	Eseg	Dseg	Cseg	Bseg	Aseg

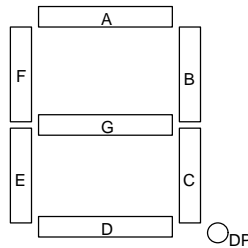

6.5. DIPSW1 READ PORT (3F-F050H [READ ONLY])

This port is used to read the status of DIPSW1 on the Base board. The data format is as shown in table below.

Bit7	Bit6	Bit5	Bit4	Bit3	Bit2	Bit1	Bit0
SW1-8	SW1-7	SW1-6	SW1-5	SW1-4	SW1-3	SW1-2	SW1-1
No use	No use	No use	No use	TIM1	TIM0	BPS1	BPS0

SW1-[8..1]: The status of SW1 on the Base board can be read. SW1-1 corresponds to switch “ 1” of DIP SW1, while SW1-8 corresponds to switch “ 8” of DIP SW1. When a bit is ON, it represents 0. When a bit is OFF, it represents 1.

Some of the DIPSW1 bits are reserved by the monitor in the ROM mounted on the Base board, as shown in table below. However, note that these functions are defined in terms of software. This means that, even when the switch setting is changed, these functions are not affected by this (hardware-based) action.

BPS1	BPS0	Baud rate when Multi monitor is used in a serial circuit
0	0	Don' t use
0	1	38400 bps
1	0	19200 bps
1	1	9600 bps

TIM1	TIM0	Timer rate
0	0	Timer not used
0	1	200 Hz (5 ms)
1	0	100 Hz (10 ms)
1	1	60 Hz (16.67 ms)

6.6. STATUS READ PORT (3F-F060H [READ ONLY])

Bit7	Bit6	Bit5	Bit4	Bit3	Bit2	Bit1	Bit0
TOVER_FLG-	TOUT1	TOUT0	MEM1M/16M-	PD4	PD3	PD2	PD1

PD[4..1]: The status of PD[4..1] of the DRAM (72-pin SIMM) mounted on the board can be read. The status of PD[2..1] indicates the size of the mounted DRAM. The relationship between PD[2..1] and the DRAM capacity is given in table below.

PD[2]	PD[1]	DRAM capacity
0	0	4 Mbytes
0	1	Reserved
1	0	16 Mbytes
1	1	8 Mbytes

PD[2..1] and DRAM Capacity

- MEM1M/16M-:** “ 0” is read when the external address space of the CPU of the Socket board is 16 Mbytes, and “ 1” is read when it is 1 Mbyte.
- TOUT0, TOUT1:** The status of the output terminals of channels 0 and 1 of the TIC (nPD71054) can be read (see Section 6.3).
- TOVER_FLG-:** This goes to “ 0” upon a time-out ready occurrence once the bus cycle count has reached 31 cycles. Use TOVER_RDY_INT_CLR (3F-F190H) to clear this flag (return it to “ 1”).

6.7. BIC (BUS INTERFACE CONTROL) (3F-F080H TO 3F-F0F0H)

The BIC is used to set the parameters related to access to ROM, SRAM, DRAM and the ports on the Base board.

Address	Bit7	Bit6	Bit5	Bit4	Bit3	Bit2	Bit1	Bit0
3F-F080H	----	----	----	----	----	----	SRAMWAIT1	SRAMWAIT0
3F-F090H	----	----	----	----	----	----	----	----
3F-F0A0H	----	----	----	----	----	----	PRCWIDE1	PCRWIDE0
3F-F0B0H	----	----	----	----	----	----	RASWIDE1	RASWIDE0
3F-F0C0H	----	----	----	----	----	----	CASRDWIDE1	CASRDWIDE0
3F-F0D0H	----	----	----	----	----	----	----	PAGEMODE
3F-F0E0H	----	----	----	----	----	----	SYSIOWAIT1	SYSIOWAIT0
3F-F0F0H	----	----	----	----	----	ROMWAIT2	ROMWAIT1	ROMWAIT0

SRAMWAIT1	SRAMWAIT0	Function
0	0	Sets the wait count for SRAM access to 0.
0	1	Sets the wait count for SRAM access to 1.
1	0	Sets the wait count for SRAM access to 2.
1	1	Sets the wait count for SRAM access to 3.

These are reset to [1,1] when the system is reset.

PRCWIDE1	PCRWIDE0	Function
0	0	Sets the RAS precharge time for DRAM access to 1 clk.
0	1	Sets the RAS precharge time for DRAM access to 2 clks.
1	0	Sets the RAS precharge time for DRAM access to 3 clks.
1	1	Sets the RAS precharge time for DRAM access to 4 clks.

These are reset to [1,1] when the system is reset.

RASWIDE1	RASWIDE0	Function
0	0	Sets the Low width of RAS for DRAM access to 1 clk.
0	1	Sets the Low width of RAS for DRAM access to 2 clks.
1	0	Sets the Low width of RAS for DRAM access to 3 clks.
1	1	Sets the Low width of RAS for DRAM access to 4 clks.

These are reset to [1,1] when the system is reset.

CASRDWIDE1	CASRDWIDE0	Function
0	0	Sets the Low width of CAS for DRAM read access to 1 clk.
0	1	Sets the Low width of CAS for DRAM read access to 2 clks.
1	0	Sets the Low width of CAS for DRAM read access to 3 clks.
1	1	Sets the Low width of CAS for DRAM read access to 4 clks.

These are reset to [1,1] when the system is reset.

PAGEMODE	Function
0	DRAM is not used in page mode.
1	DRAM is used in page mode.

This is reset to [0] when the system is reset.

SYSIOWAIT1	SYSIOWAIT0	Function
0	0	(Sets the wait count for SYSTEM-I/O access to 8.)
0	1	Sets the wait count for SYSTEM-I/O access to 1.
1	0	Sets the wait count for SYSTEM-I/O access to 2.
1	1	Sets the wait count for SYSTEM-I/O access to 3.

These are reset to [1,1] when the system is reset.

ROMWAIT2	ROMWAIT1	ROMWAIT0	Function
0	0	0	Sets the wait count for ROM access to 8.
0	0	1	Sets the wait count for ROM access to 1.
0	1	0	Sets the wait count for ROM access to 2.
0	1	1	Sets the wait count for ROM access to 3.
1	0	0	Sets the wait count for ROM access to 4.
1	0	1	Sets the wait count for ROM access to 5.
1	1	0	Sets the wait count for ROM access to 6.
1	1	1	Sets the wait count for ROM access to 7.

These are reset to [1,1,1] when the system is reset.

See Chapter 7 for details of the recommended settings related to the wait state and DRAM.

See Section 12.2 for an explanation of the significance of the DRAM-related settings.

6.8. NMI SELECT PORT (3F-F140H TO 3F-F150H)

This port controls the generation of the NMI signal. See Section 9.2 for details of the NMI signal generation logic.

Address	Bit7	Bit6	Bit5	Bit4	Bit3	Bit2	Bit1	Bit0
3F-F140H	----	----	----	----	ISACOM_NMIEN	PRT_NMIEN	UART2_NMIEN	UART1_NMIEN
3F-F150H	----	----	----	----	Reserved (0)	TIMER_NMIEN	TOVER_NMIEN	EXTBUS_NMIEN

Set each bit to " 1" when NMI is to be generated according to the corresponding interrupt request, or to " 0" when NMI need not be generated.

UART1_NMIEN:	Interrupt request issued by UART-CH#1 of TL16C552A
UART2_NMIEN:	Interrupt request issued by UART-CH#2 of TL16C552A
PRT_NMIEN:	Interrupt request issued by PRINTER of TL16C552A
ISACOM_NMIEN:	Interrupt request based on communication with ISA bus
EXTBUS_NMIEN:	Interrupt request received from EXTBUS
TOVER_NIMEN:	Interrupt request resulting from time-over ready occurrence
TIMER_NIMEN:	Interrupt request issued by TOUT0 of nPD71054

Reserved (0): This bit is reserved and should be set to “ 0” .

6.9. NMI STATUS PORT (3F-F160H TO 3F-F170H [READ ONLY])

This port is used to identify the source of an NMI request. See Section 9.2 for details of the NMI signal generation logic.

Address	Bit7	Bit6	Bit5	Bit4	Bit3	Bit2	Bit1	Bit0
3F-F160H	----	----	----	----	ISACOM_NMI	PRT_NMI	UART2_NMI	UART1_NMI
3F-F170H	----	----	----	----	----	TIMER_NMI	TOVER_NMI	EXTBUS_NMI

Each bit is set to “ 1” when NMI is generated by the corresponding interrupt request, or set to “ 0” when it need not be generated. Each bit represents the interrupt request status of each interrupt request source and is not affected by the settings of the NMI enable port. Therefore, the interrupt factor causing the NMI occurrence can be identified by ANDing the information in the NMI status port with that in the NMI select port.

UART1_NMI:	Interrupt request issued by UART-CH#1 of TL16C552A
UART2_NMI:	Interrupt request issued by UART-CH#2 of TL16C552A
PRT_NMI:	Interrupt request issued by PRINTER of TL16C552A
ISACOM_NMI:	Interrupt request based on communication with ISA bus
EXTBUS_NMI:	Interrupt request received from JEXT bus
TOVER_NMI:	Interrupt request resulting from time-over ready occurrence
TIMER_NMI:	Interrupt request issued by TOUT0 of nPD71054

6.10. NMI/INT0/INT1 MASK PORT (3F-F180H)

This port controls the final masking of NMI, INT0 and INT1. See Section 9.2 for details of the NMI signal generation logic and Section 9.3 for the maskable interrupt generation logic.

Address	Bit7	Bit6	Bit5	Bit4	Bit3	Bit2	Bit1	Bit0
3F-F180H	----	----	----	----	----	INT1_MASK	INT0_MASK	NMI_MASK

NMI_MASK:	Set “ 1” to mask the NMI signal to the CPU or “ 0” when it need not be masked.
INT0_MASK:	Set “ 1” to mask the INT0(P22/INTP01) signal to the CPU or “ 0” when it need not be masked.
INT1_MASK:	Set “ 1” to mask the INT1 (P24/INTP03) signal to the CPU or “ 0” when it need not be masked.

6.11. NMI/INT1 REQUEST CLEAR PORTS (3F-F190H, 3F-F1A0H [WRITE ONLY])

When there are latched interrupts among the NMI/INT1 request factors, these ports allow the latched requests to be cleared.

Address	Write
3F-F190H	Clears the NMI/INT1 request resulting from the time-over ready occurrence (see Section 12.1).
3F-F1A0H	Clears the NMI/INT1 request issued by TOUT0 of nPD71054.

6.12. INT0(P22/INTP01) SELECT PORT (3F-F200H)

This port controls the generation of the INT0(P22/INTP01) signal. See Section 9.3 for details of the INT0 signal generation logic.

Address	Bit7	Bit6	Bit5	Bit4	Bit3	Bit2	Bit1	Bit0
3F-F200H	----	----	----	----	----	PRT_INT0EN	ISACON_INT0EN	UART1_INT0EN

Set each bit to “ 1” to generate INT0(P22/INTP01) according to the corresponding interrupt request, or to “ 0” when it need not be generated.

UART_INT0EN: Interrupt request issued by UART-CH#1 of TL16C552A

ISACOM_INT0EN: Interrupt request based on communication with ISA bus

PRT_INT0EN: Interrupt request issued by PRINTER of TL16C552A

6.13. INT1 (P24/INTP03) SELECT PORT (3F-F210H)

This port controls the generation of the INT1 (P24/INTP03) signal. See Section 9.3 for details of the INT0 signal generation logic.

Address	Bit7	Bit6	Bit5	Bit4	Bit3	Bit2	Bit1	Bit0
3F-F210H	----	----	----	----	----	Reserved (0)	TOVER_INT1EN	TIMER_INT1EN

Set each bit to “ 1” to generate INT1 (P24/INTP03) according to the corresponding interrupt request, or to “ 0” when it need not be generated.

TIMER_INT1EN: Interrupt request issued by TOUT0 of nPD71054

TOVER_INT1EN: Interrupt request resulting from time-over ready occurrence

Reserved (0): This bit is reserved and should be set to “ 0” .

6.14. INT0(P22/INTP01) STATUS PORT (3F-F220H [READ ONLY])

This port is used to identify the source of an INT0(P22/INTP01) request. See Section 9.3 for details of the INT0 signal generation logic.

Address	Bit7	Bit6	Bit5	Bit4	Bit3	Bit2	Bit1	Bit0
3F-F220H	----	----	----	----	----	PRT_INT0	ISACON_INT0	UART1_INT0

Each bit is set to “ 1” when INT0 is generated by the corresponding interrupt request, or set to “ 0” when it is not generated. Each bit represents the interrupt request status of each interrupt request source and is not affected by the settings of the INT0 enable port. Therefore, the interrupt factor causing the INT0 occurrence can be identified by ANDING the information in the INT0 status port with that in the INT0 select port.

UART1_INT0: Interrupt request issued by UART-CH#1 of TL16C552A

ISACOM_INT0: Interrupt request based on communication with ISA bus

PRT_INT0: Interrupt request issued by PRINTER of TL16C552A

6.15. INT1 (P24/INTP03) STATUS PORT (3F-F230H [READ ONLY])

This port is used to identify the source of an INT1 (P24/INTP03) request. See Section 9.3 for details of the INTO signal generation logic.

Address	Bit7	Bit6	Bit5	Bit4	Bit3	Bit2	Bit1	Bit0
3F-F230H	----	----	----	----	----	----	TOVER_INT1	TIMER_INT1

Each bit is set to “ 1” when INT1 is generated by the corresponding interrupt request, or set to “ 0” when it need not be generated. Each bit represents the interrupt request status of each interrupt request source and is not affected by the settings of the INT1 enable port. Therefore, the interrupt factor causing the INT1 occurrence can be identified by ANDing the information in the INT1 status port with that in the INT1 select port.

TIMER_INT1: Interrupt request issued by TOUT0 of nPD71054

TOVER_INT1: Interrupt request resulting from time-over ready occurrence

7. RECOMMENDED SETTINGS

This chapter specifies the recommended values for the parameters related to access to memory resources.

7.1. CPU SETTING

No restrictions are imposed on the settings of the bus control function built into the CPU. Therefore, to maximize the bus performance, set DWC (0xFFFF to F060) of SFR to 0x0000 and BCC (0xFFFF to F062) to 0x0000.

7.2. SRAM/ROM

The table below lists the recommended wait counts when SRAM and ROM with an access time of 120 ns/150 ns is used.

	SRAM wait count	ROM (120 ns) wait count	ROM (150 ns) wait count
25 MHz	0	3	3

7.3. DRAM

The table below lists the recommended settings when DRAM with an access time of 60 ns/70 ns is used.

Access time	CPU	RAS precharge time	RAS width	Read cycle CAS width
60 ns	25 MHz	1 CLK	2 CLKs	2 CLKs
70 ns	25 MHz	2 CLKs	2 CLKs	2 CLKs

7.4. SYSTEM-I/O WAIT COUNT

The table below lists the recommended wait counts for the SYSTEM-I/O. The SYSTEM-I/O wait count is determined by the access time of the nPD71054, which is slowest in the SYSTEM-I/O space.

	SYSTEM-I/O wait count
25 MHz	2

7.5. SYSTEM-I/O COMMAND RECOVERY TIME

Access by the TL16C552A and nPD71054 should satisfy the command recovery time requirement. Therefore, when accessing the TL16C552A or nPD71054 continuously, a second access must be performed a certain amount of time after the first access.

As the TL16C552A and nPD71054 share the same command signals (RD-/WR-), the recovery time is determined by the nPD71054, this requiring the longest recovery time.

The recovery time is generated by performing read access to a memory resource other than the TL16C552A or nPD71054. The memory resource which is recommended to be read-accessed for generating the recovery time is the DIPSW1 read port (3F-F050H).

Therefore, generate the DIPSW1 read port read cycles the number of times specified in the table below, immediately after accessing the TL16C552A or nPD71054.

	DIPSW1 read port read cycle
SYSTEM-I/O command recovery time	Two times (independent of the CPU operating frequency)

Remember that no write cycles must be generated on the external extension bus of the V852 until the recovery time requirement has been satisfied after accessing the TL16C552A or nPD71054. Therefore, recovery time generation processing should not be given as a subroutine but should be given as a macro in case such a subroutine proves necessary. If a subroutine is used, a stack write would occur before the read cycle for recovery time generation, and a write cycle would occur in the external extension bus depending on the position of this stack

8. JEXT BUS SPECIFICATION

The JEXT is a connector which is used to expand memory and I/O units. The local bus on this board is connected to the JEXT connector.

The following tables list the pin arrangement of the JEXT connector and the functions of each signal. The timing relationships between the signals are also shown below.

Number	Signal name	Number	Signal name	Number	Signal name	Number	Signal name
1	+5V	2	+5V	31	GND	32	GND
3	D0	4	D1	33	A8	34	A9
5	D2	6	D3	35	A10	36	A11
7	D4	8	D5	37	A12	38	A13
9	D6	10	D7	39	A14	40	A15
11	GND	12	GND	41	+5V	42	+5V
13	D8	14	D9	43	A16	44	A17
15	D10	16	D11	45	A18	46	A19
17	D12	18	D13	47	BHE-	48	GND
19	D14	20	D15	49	GND	50	RD-
21	+5V	22	+5V	51	WR-	52	RESET-
23	A0	24	A1	53	GND	54	GND
25	A2	26	A3	55	READY	56	INT-
27	A4	28	A5	57	GND	58	GND
29	A6	30	A7	59	CPUCLK	60	GND

JEXT Connector Pin Arrangement

Signal name	Input/output	Function
A[0..19]	Output	Address bus signal, which is originally the CPU address signal received at a buffer.
BHE-	Output	Byte high enable signal, which is originally the CPU UBE- signal received at a buffer.
D[0..15]	Input/ output	Data bus signal, which is originally the CPU data bus signal received at a buffer. It is pulled up with a 10 kΩ resistor on the board.
RD-	Output	Read cycle timing signal, which becomes active only when the JEXT space is accessed.
WR-	Output	Write cycle timing signal, which becomes active only when the JEXT space is accessed.
READY	Input	Signal indicating the end of a cycle. It is valid only for the JEXT space. To have the CPU recognize READY securely, it is necessary to keep READY active until RD- or WR- becomes inactive. It is pulled up with a 10 kΩ resistor on the board.
INT-	Input	Active-low interrupt request signal, which is connected to the P23/INTP02 pin of the CPU via a buffer and the NMI pin of the CPU via a mask logic. It is pulled up with a 10 kΩ resistor on the board.
RESET-	Output	Active-low system reset signal
CLK	Output	Clock signal, which is connected to the CLKOUT pin of the V852 via a buffer.

JEXT Connector Signals

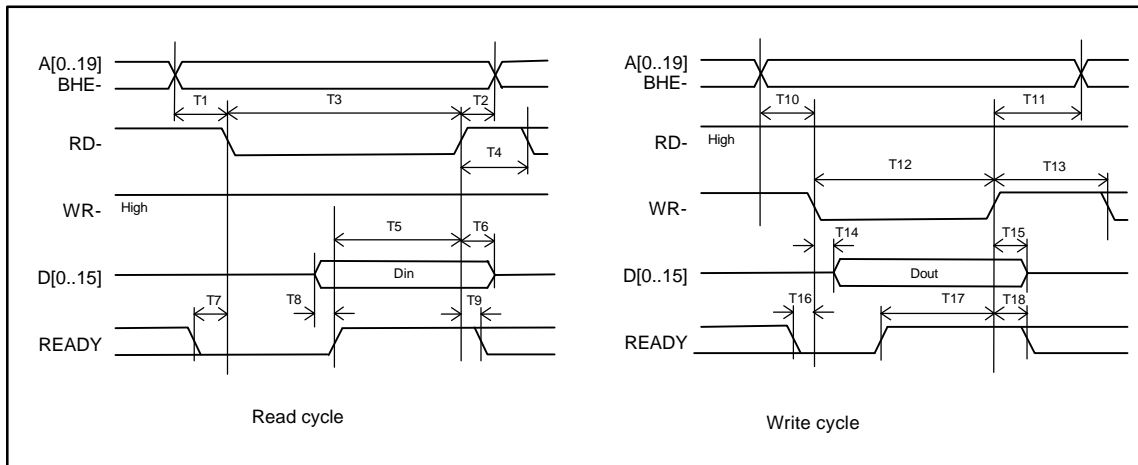

JEXT Bus Cycle

Symbol	Description	Min. (ns)	Max. (ns)
T1	RD address setup time	0	
T2	RD address hold-up time	0	
T3	RD cycle time	50	
T4	RD cycle interval	20	
T5	RD data setup time	15	
T6	RD data hold time	0	
T7	RD READY WAIT setup time	0	
T8	RD READY setup time	0	
T9	RD READY hold time	0	
T10	WR address setup time	0	
T11	WR address hold time	20	
T12	WR cycle time	50	
T13	WR cycle interval	20	
T14	WR data delay time		20
T15	WR data hold time	20	
T16	WR READY WAIT setup time	0	
T17	WR READY setup time	0	
T18	WR READY hold time	0	

JEXT Bus AC Specifications

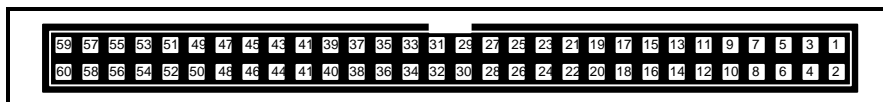

JEXT Pin Arrangement

9. OTHER CPU RESOURCES

9.1. RESET-

The factors listed below trigger a CPU reset. These factors reset the CPU. They also system-reset the board control circuit.

- **Power-on reset:** Occurs when the power to the board is switched on.
- **Reset request received from JROMEM:** Input to the RESET- pin of the JROMEM connector on the Base board. See Section 3.19 for details.
- **Reset by the SWRESET:** Generated by the reset switch (SWRESET) on the rear panel of the base board.
- **Reset by RESET_SW:** Generated by pressing the reset switch (RESET_SW) on the Socket board.
- **Reset request from the host:** Sent via the ISA bus.

The figure below outlines the reset signal generation logic.

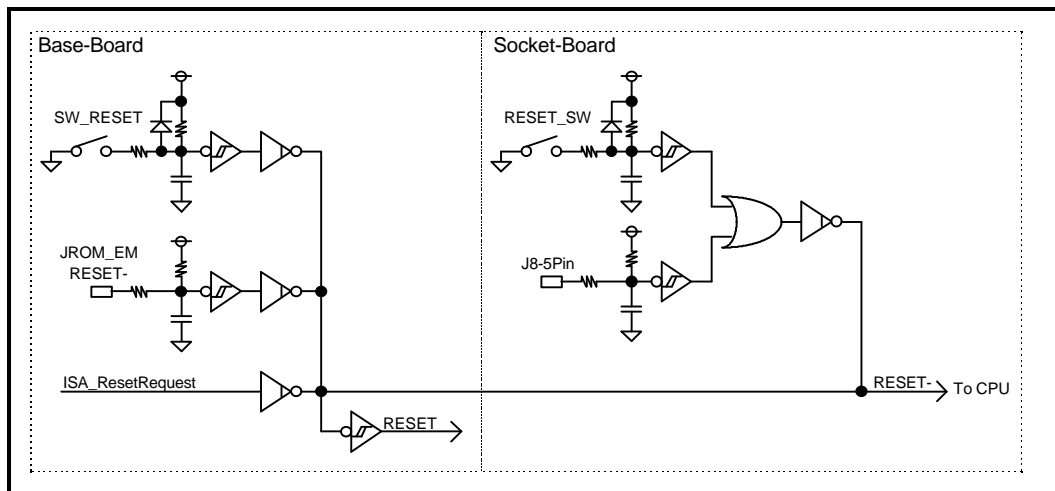

9.2. NMI-

An NMI to the CPU occurs as follows:

- **Request received from controller on the Base board:** An NMI can be generated by an interrupt request received from the UART/PRINT controller (TL16C552A) on the Base board (see Section 6.2).

An NMI can also be generated based on the interrupt request received from the timer (nPD71054) on the Base board (see Section 6.3). This interrupt is used by the Multi debugger functions such as the profiler function (see Section 6.11).

Which of the above interrupt requests is to be connected to the NMI can be controlled by programming (see Section 6.8).

- **Request based on Ready time-over:** Time-out Ready occurs when a bus cycle has not been completed within a certain period. It is possible to generate an NMI request upon the occurrence of the time-out ready status (see Section 6.8).
- **Request received from JEXT bus:** NMI can be generated when the INT signal of the JEXT bus goes active (see Section 6.8).

- **NMI request from JROMEM:** NMI is generated by the input to the NMI pin of the JROMEM connector on the Base board. See Section 3.19 for details.
- **Request received from ISA bus:** NMI can be used for controlling communications via the ISA bus. This NMI is used when the Multi debugger is connected through the ISA bus.
- **Request by NMI_SW:** NMI is generated when the NMI switch (NMI_SW) on the Socket board is pressed.

It is possible to mask the NMI by means of hardware. See Sections 6.8 and 6.10 for an explanation of the masking method.

The following procedure must be applied when an NMI occurs.

- ① Mask the NMI by means of hardware by setting NMIMASK of the NMI mask port to " 1" .
- ② Determine the NMI request source. This can be identified at the NMI status port (see Section 6.9).
- ③ Clear the request by performing NMI processing for the request source.
- ④ Reset the mask by setting NMIMASK of the NMI mask port to " 0" .
- ⑤ Return from NMI processing.

The figure below outlines the NMI generation logic.

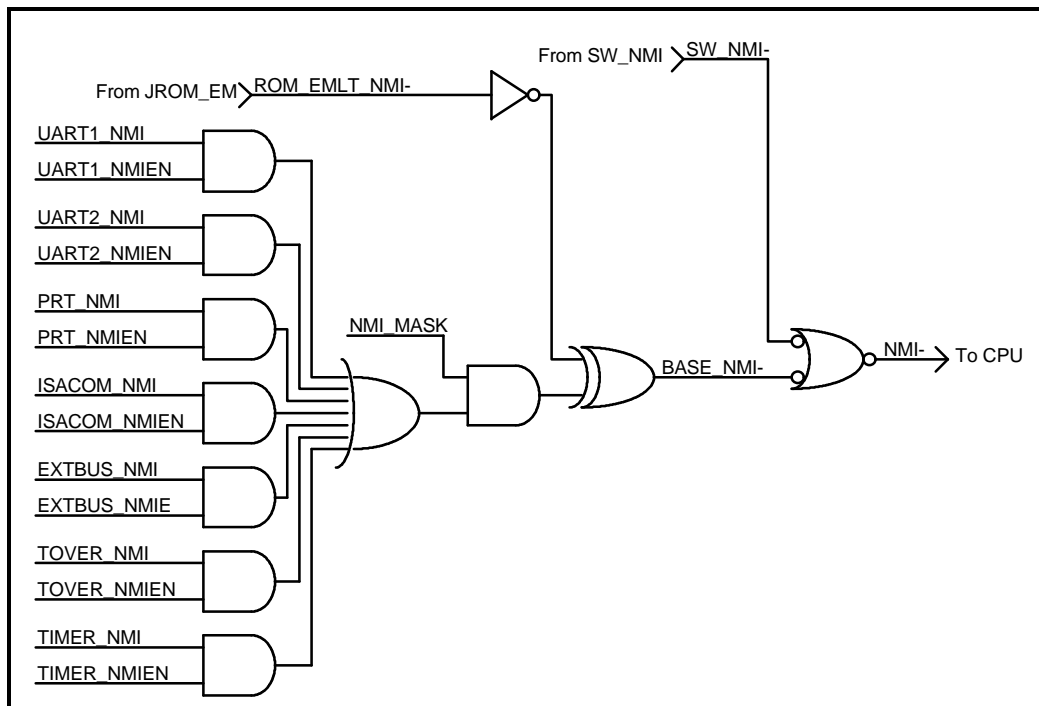

9.3. MASKABLE INTERRUPTS (INT0(P22/INTP01), INT1 (P24/INTP03))

The factors listed below trigger INT0 (P00/INTP00). See Section 6.12 for details of selecting an interrupt.

- **Request from controller on the Base board:** INT0 (P22/INTP01) can be generated by the UART-CH#1 or PRINTER interrupt request received from the UART/PRINT controller (TL16C552A) on the Base board (see Section 6.2).
- **Request from ISA bus:** INT0 (P22/INTP01) can be used for controlling communications via the ISA bus.

The factors listed below trigger INT1 (P24/INTP03). See Section 6.13 for details of selecting an interrupt.

- **Request received from controller on the Base board:** INT1 (P24/INTP03) can be generated by an interrupt request received from the timer (nPD71054) on the Base board (see Sections 6.3 and 6.11).
- **Request based on Ready time-over:** Time-out Ready occurs when a bus cycle has not been completed within a certain period. It is possible to generate INT1 (P24/INTP03) upon the occurrence of the time-out ready signal (see Section 6.11).

It is possible to mask INT0/INT1 by means of hardware. See Section 6.10 for an explanation of the masking method.

The following procedure must be applied when an INT0/INT1 occurs.

- ① Mask the INT0/INT1, by means of hardware, by setting INT0MASK or INT1MASK of the NMI/INT0/INT1 mask port to " 1" .
- ② Determine the INT0/INT1 request source. This can be identified at the INT0 or INT1 status port (see Sections 6.14 and 6.15).
- ③ Clear the request by performing interrupt processing for the request source.
- ④ Reset the mask by setting INT0MASK or INT1MASK of the NMI/INT0/INT1 mask port to " 0" .
- ⑤ Return from NMI processing.

The figure below outlines the INT0/INT1 generation logic.

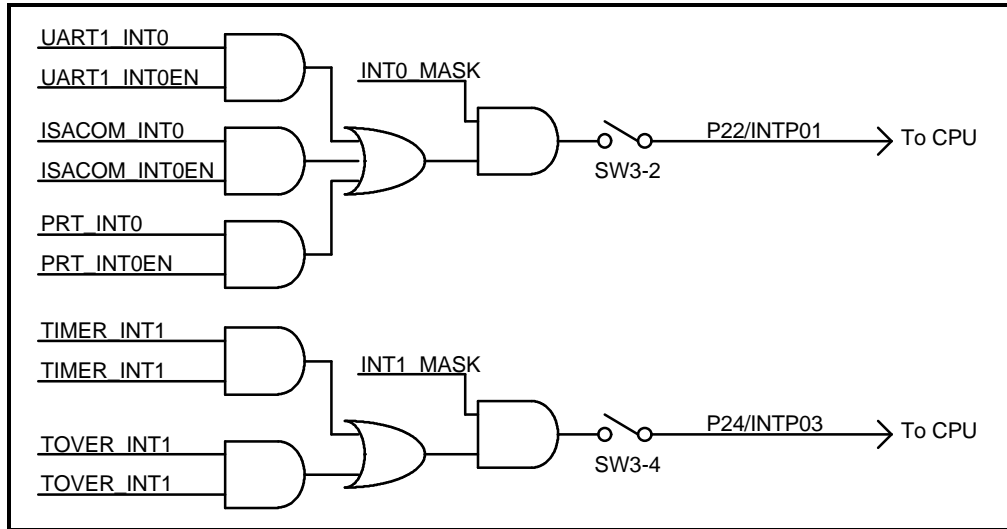

9.4. PORT

Among the CPU ports, P4[0..7], P5[0..7], P6[0..3] and P9[0..6], which are related to the external extension bus, are used for connection to the Base board.

Other ports including P0[0..7], P1[0..7], P2[0..7], P3[0..7], and P10[0..3] are connected to the connectors on the Socket board. They can be used as desired by the user. See Section 3.5 for details the pin arrangements of the connectors and Chapter 13 for details of the connections on the board.

10. Multi MONITOR

The ROM chip on the board is incorporated with the Multi monitor. The following cautions should be observed when the board is connected to the Multi server as the host.

10.1. MONITOR WORK RAM

The monitor uses the first 32-KB (1F-8000H to 1F-EFFFH) area in the SRAM as work RAM. In other words, user programs are not allowed to use logical addresses xF-8000H to xF-EFFFH (x: 0 to 1). (See Section 5.1.)

10.2. INTERRUPTS

When running on the Multi monitor, user programs cannot use interrupts at present.

10.3. _INIT_SP SETTING

_INIT_SP (stack pointer initial value) is set to 1F-7FFCH (immediately before the monitor work RAM) by the monitor. (_INIT_SP can be changed in the Multi environment.)

10.4. REMOTE CONNECTION

Either serial or ISA bus connection can be selected for operation with the Multi server. To switch from serial connection to ISA bus connection or vice versa, it is necessary to reset the monitor (by pressing the reset switch on the rear panel) and run the Check RTE utility of RTE for Windows.

10.5. TIMER INTERRUPT

The profiler function of the Multi debugger cannot be used if timer interrupt is inhibited (see Section 4.1 for details of timer interrupt setting).

The characteristics of the CPU used with the V852 make it necessary to use a timer interrupt for the break point function. Therefore, the Multi debugger cannot be used if timer interrupt is inhibited.

11. RTE COMMANDS

When the monitor and server (rteserv) are connected, the TARGET window is opened. The RTE commands can be issued in this window. The following table lists the RTE commands.

Command	Description
HELP or ?	Displays help messages.
INIT	Initializes.
VER	Displays the version number.
SFR	Changes or displays the internal register (SFR).

RTE Commands

Some commands require parameters. All numeric parameters such as addresses and data are assumed to be hexadecimal numbers. The following numeric representations are invalid:

0x1234 1234H \$1234

11.1. HELP (?)

<Format> HELP [command-name]

Displays a list of RTE commands and their formats. A question mark (?) can also be used in place of the character string HELP. If no command name is specified in the parameter part, the HELP command lists all usable commands.

<Example> HELP SFR

Displays help messages for the SFR command.

11.2. INIT

<Format> INIT

Initializes the RTE environment. Usually, this command should not be used.

11.3. VER

<Format> VER

Displays the version number of the current RTE environment.

11.4. SFR

<Format> SFR[register-name[data]]

Displays the data in the CPU' s internal register (SFR) or writes data into it.

When the parameters are omitted, this command displays a list of register names which can be specified with the SFR command.

When only the register-name parameter is specified, this command reads and displays the data in the specified register.

When both the register-name and data parameters are specified, this command writes the data into the specified register.

Specifying a display command for a read-inhibited register or a write command for a write-inhibited register results in an error. The access size for read or write is automatically set to the same size as that of the register.

12. APPENDIX BUS CYCLE

12.1. TIME-OVER READY

On the Base board, when an external bus cycle generated by the CPU has not been completed within a certain period, the time-over ready status is generated to forcibly complete the cycle. Time-over ready is generated when a bus cycle has been generated continuously for 1024 clocks (approx. 30.7 ns when operating at 33 MHz).

When time-over ready occurs, the TOVER LED on the Base board lights and the NMI and INT1 (P24/INTP03) interrupt factor is generated. The TOVER LED goes out, and the NMI and INT1 (P24/INTP03) interrupt factor can be cleared by writing to the NMI/INT1 request clear port.

See Sections 3.18, 6.8, 6.11 and 6.13 for details.

12.2. DRAM INTERFACE

12.2.1. Outline

DRAM access supports both normal mode and page mode.

In page mode, the RAS signal issued to the DRAM is held active as long as access to the same row address continues and access is performed by controlling only the CAS signal. This makes it possible to reduce the access time for continuous access to the same row address. If, however, an access to another row address is generated, the access time becomes slower when continuous access fails because the RAS signal is deactivated after the start of the cycle and access is started only after the completion of RAS precharge.

Therefore, whether normal or page mode can provide the better performance depends on the number of times continuous access to DRAM occurs.

Normal or page mode can be set by programming (see Section 6.7).

12.2.2. Signal Description

The signals used for waveforms described in this chapter are defined as follows:

CLKOUT: System clock output by the CPU.

ASTB: External address strobe signal output by the CPU.

DSTB-: External data strobe signal output by the CPU.

WAIT-: Wait signal input to the CPU.

HIT: Signal that indicates whether a row address is the same as one used in the previous cycle, because the DRAM is used in the page mode. This signal is generated by the DRAM control circuit.

RAS-: RAS signal input to the DRAM.

CASn-: CAS signal input to the DRAM. One CAS- signal is provided for each byte in the word (hence, CAS0- to CAS3-).

WE-: WE signal input to the DRAM.

12.2.3. Single Read (Normal Mode)

In normal mode, read cycles always occur as single read cycles, as shown in the following timing chart.

- In this timing chart, two read cycles are generated successively after the completion of RAS precharge of the previous cycle. The second of these cycles is kept waiting during RAS precharging.
- Xclk, Yclk and Zclk represent, respectively, the clock counts for the “ RAS precharge time,” “ RAS Low width,” and “ CAS Low width in read access” which are set in the program (see Section 6.7).
- When the “ RAS minimum low width” setting is larger, by two or more, than the “ CAS Low width in read access,” Zclk becomes equal to (Yclk - 1).

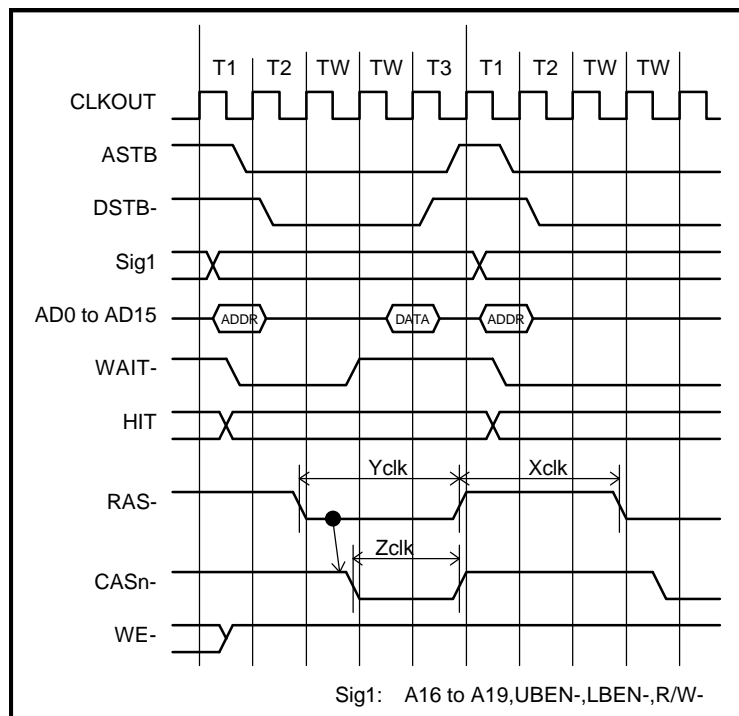

12.2.4. Single Write (Normal Mode)

In normal mode, write cycles always occur as single write cycles, as shown in the following timing chart.

- In this timing chart, two write cycles are generated successively after the completion of RAS precharge of the previous cycle. The second of these cycles is kept waiting during RAS precharging.
- Xclk and Yclk represent, respectively, the clock counts for the “ RAS precharge time” and “ RAS Low width,” which are set in the program (see Section 6.7).

The “ CAS Low width in write access” is always one clock.

- When the “ RAS minimum low width” setting is two clocks or larger, the “ CAS Low width in write access” becomes equal to (Yclk - 1).

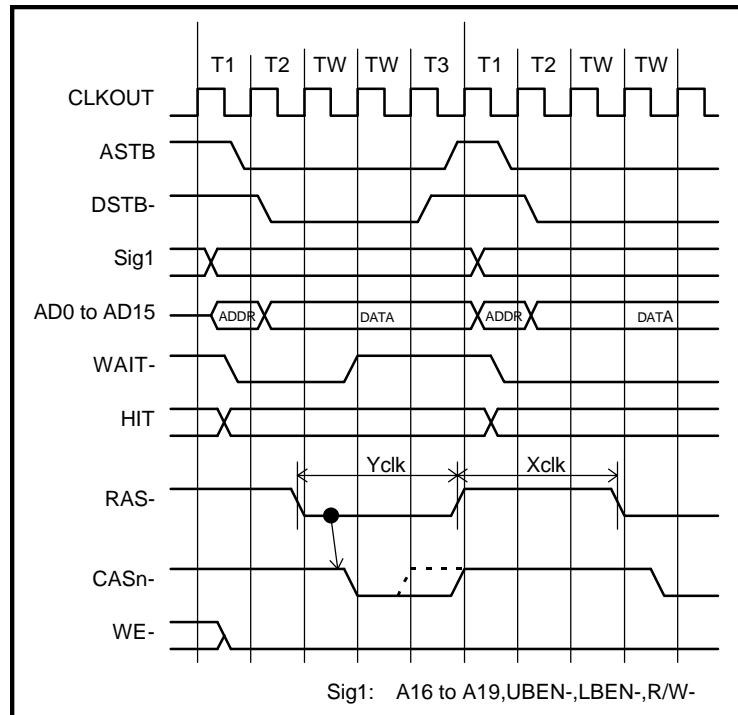

12.2.5. Page Access (Page Mode, Same Row Address)

In the page mode cycle, continuous access to the same row address is performed by controlling only the CAS signal while keeping the RAS signal active, as shown in the following timing chart.

- In this timing chart, those cycles which access the same row address are generated in the order of read, write then read, after the completion of RAS precharge of the previous cycle.
- Zclk represents the clock count for the " CAS Low width in read access" (see Section 6.7). The " CAS Low width in write access" is always one clock.
- When the " RAS minimum low width" (Yclk) setting is larger, by two or more, than the " CAS Low width in read access," Zclk of the first cycle of the access of the same row address becomes equal to (Yclk - 1).
- Accessing the same row address in page mode allows the access time to be increased by at least one wait state compared to when page mode is not used. The access speed can be further increased if the clock count for the " RAS precharge time" is more than two clocks.

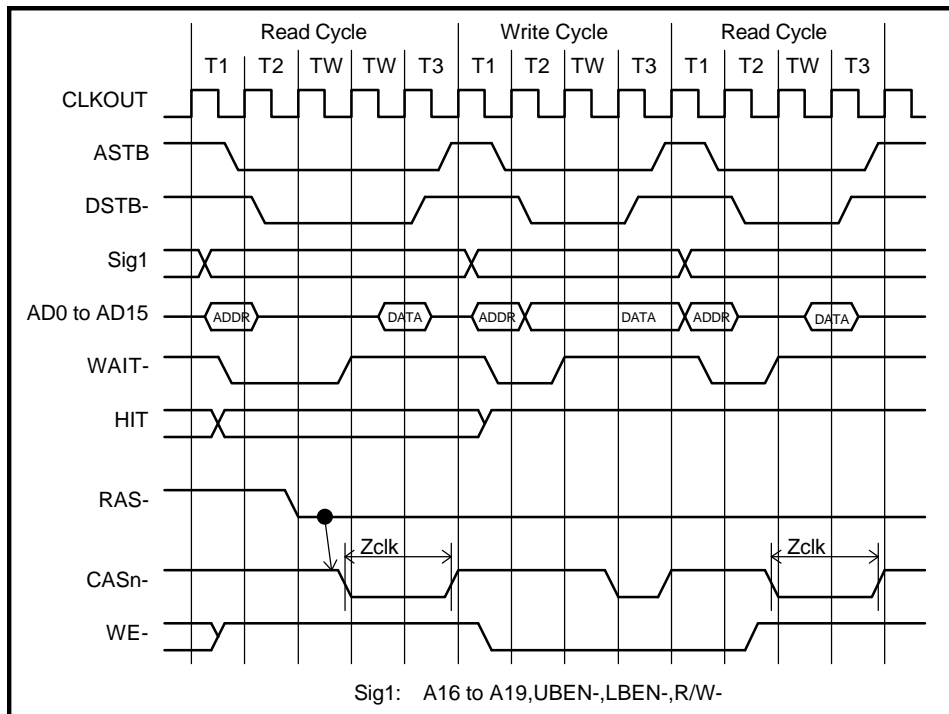

12.2.6. Page Access (Page Mode, Different Row Addresses)

When a different row address from the previously-accessed row address is accessed in page mode, the RAS signal is deactivated from the start of the cycle and activated again after having waited for a period equal to the RAS signal precharge time, as shown in the following timing chart.

- In this timing chart, two ready cycles for the same row address occur after the completion of RAS precharge of the previous cycle, then a ready cycle for a different row address occurs.
- Xclk and Zclk represent, respectively, the clock counts for the “ RAS precharge time” and “ CAS Low width in read access,” which are set in the program (see Section 6.7).
- When the “ RAS minimum low width” (Yclk) setting is larger, by two or more, than the “ CAS Low width in read access,” Zclk of the first cycle of the accesses to the same row address becomes equal to (Yclk - 1).

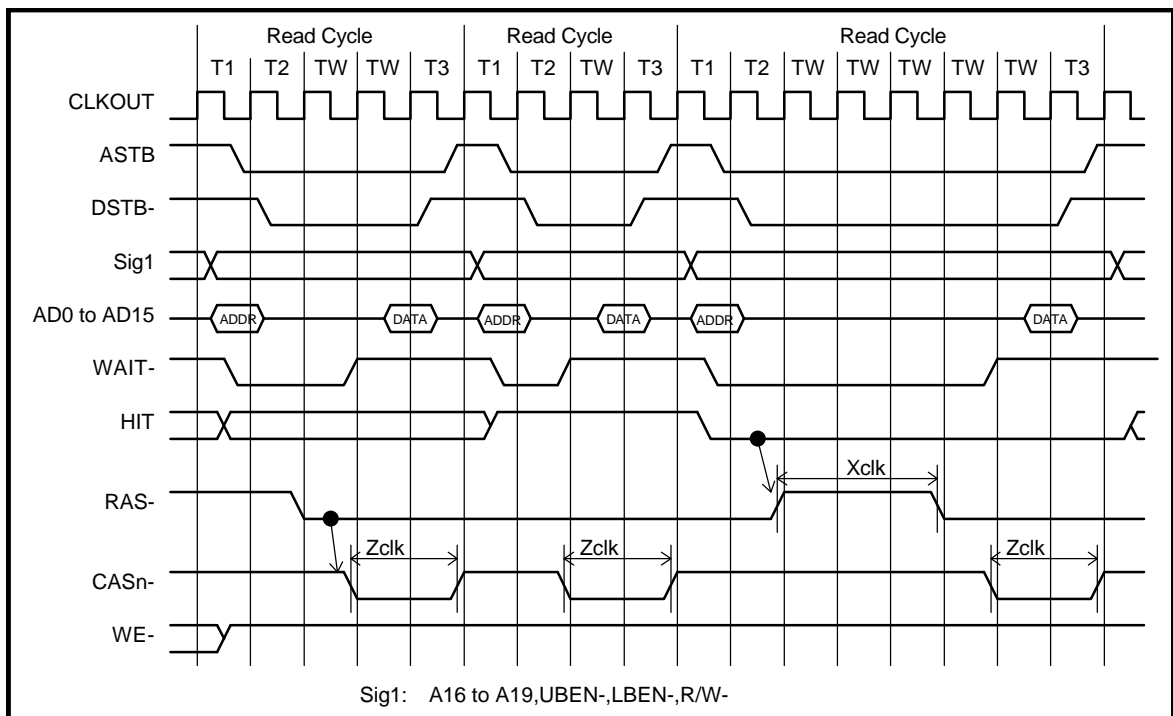

13. APPENDIX CPU PORT CONNECTIONS

This chapter describes the connection schemes of the CPU ports which are connected to the connectors on the Socket board.

13.1. P00 TO P07

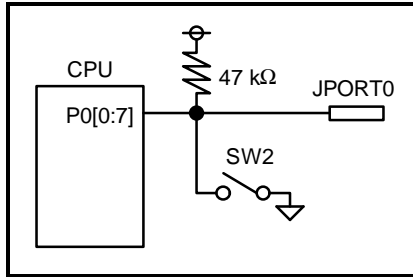

13.2. P10 TO P17

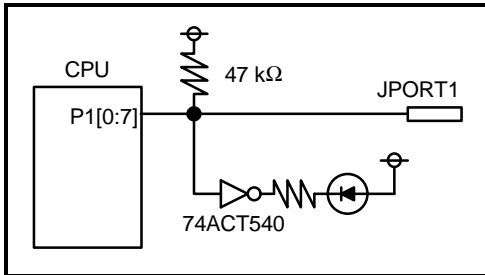

13.3. P20 TO P27

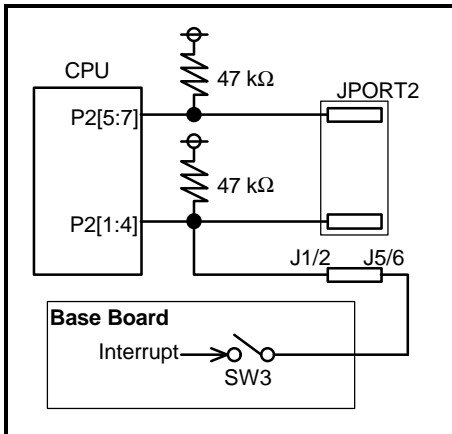

13.4. P30 TO P37

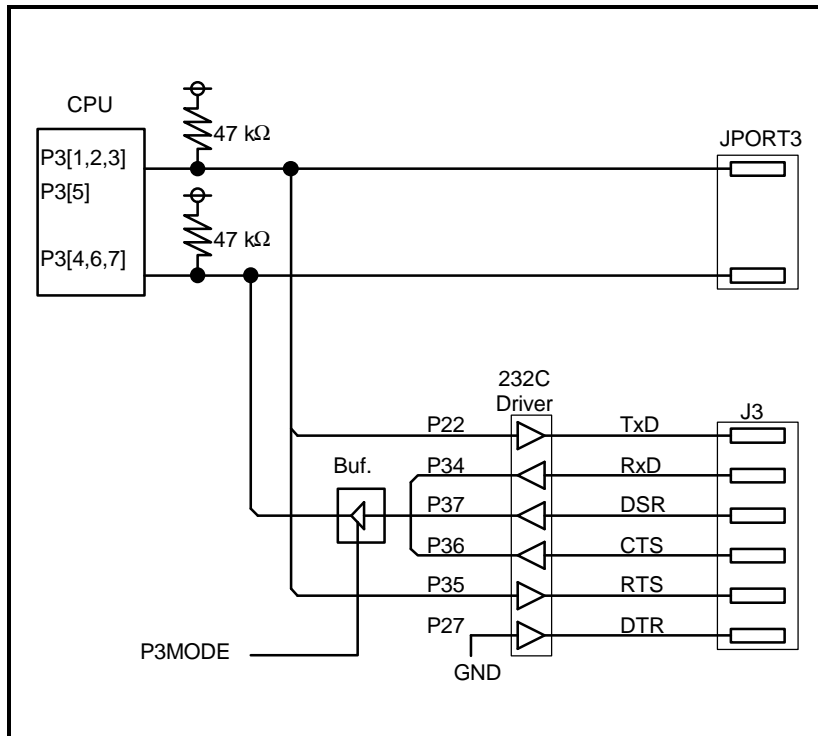

13.5. P100 TO P103

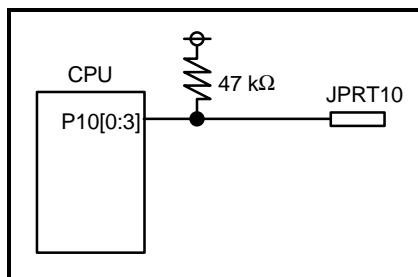

- Memo -

RTE-V852-PC User' s Manual
Created on August 15, 1996. Rev. 1.00

M662MNL02

Midas lab